

Robotic & Grinding Solutions

TOOLS AND STATIONS CATALOG

Standard tools and stations offered by Z3D have been developed over many years and are used in machines currently employed in various production processes. The product line includes part presentation mechanisms, grinding and polishing stations, cutting heads, end effectors, tool magazines and docking nests, and more.

Customers are able to put together entire automated cells using Z3D's standard tools and stations. This catalog illustrates the wide variety of tools and stations available, so please browse our selection and contact sales@z3dsolutions.com with any inquiries.

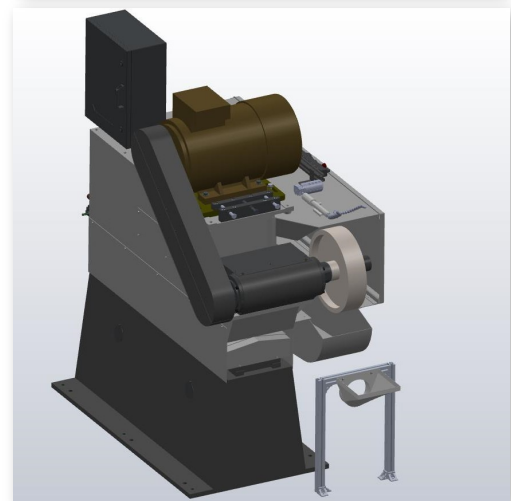
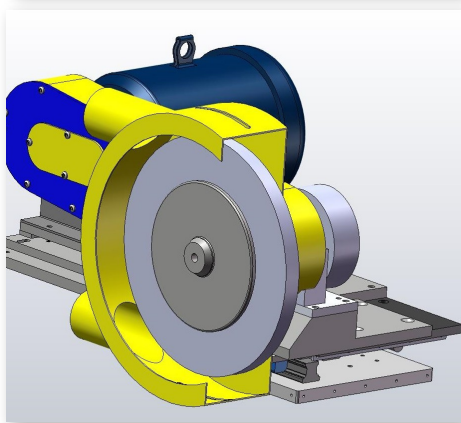
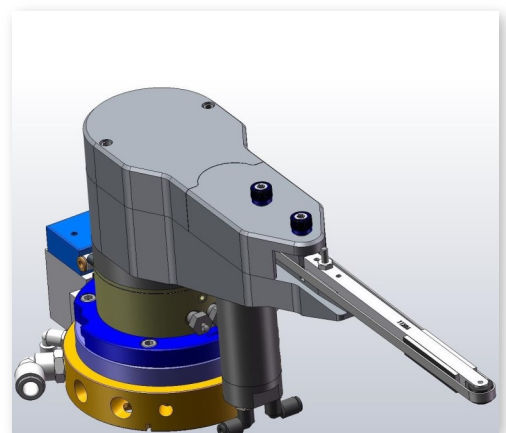
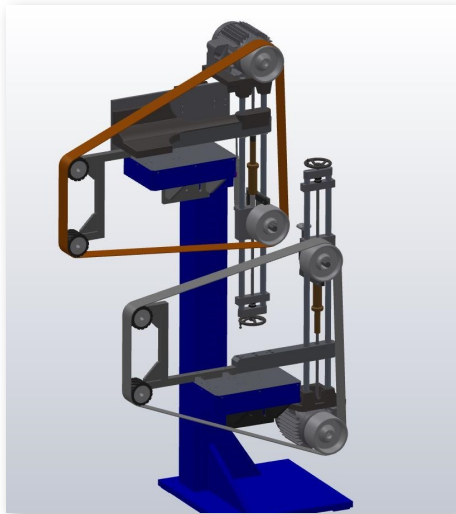

Z3D SOLUTIONS LLC

Phone: 860-314-1557
www.z3dsolutions.com
sales@z3dsolutions.com

Business Mailing Address
20 Crocus Lane
Avon, CT 06001
USA



TOOLS AND STATIONS

Part Presentation:

| | |
|----------------------------------------|----|
| ● Drawers and Conveyors..... | 3 |
| ● Rotary Table and Indexers..... | 4 |
| ● Belt Stations..... | 9 |
| ● Spindle Stations..... | 12 |
| ● Wheel and Cutoff Heads..... | 15 |
| ● Tool Magazine and Docking Nests..... | 19 |

End of Arm:

| | |
|-------------------------------------------|----|
| ● Tools..... | 23 |
| ● Grippers..... | 27 |
| ● Buffing Tools and Stations..... | 29 |
| ● Disk Handling and Sandpaper Feeder..... | 31 |
| ● Custom Engineered Solutions..... | 33 |

PART PRESENTATION:

Drawers and Conveyors

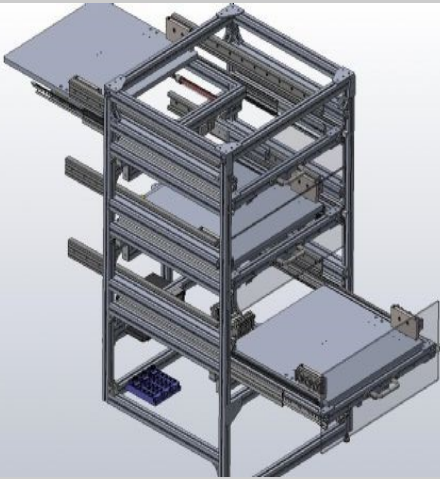

TRIPLE DRAWER, VERTICAL - MODEL: DRW-3V-18296

Drawer system made of 3 drawers arranged in vertical configuration. Each drawer can be manually opened outside the cell by the operator and extends automatically inside the cell as commanded from robot part programs. Flush attachment to the robot cells maximizes usage of cell footprint.

- 24"x24" (610x610 mm) tooling plate size
- 200 lbs (90 kg) load per drawers
- Up to 34 inches (860 mm) of extension inside the cell
- 24 inch (610 mm) opening outside. Sensors for every position
- Available controls are: none, discrete I/O, ethernet I/P, Profibus, Devicenet

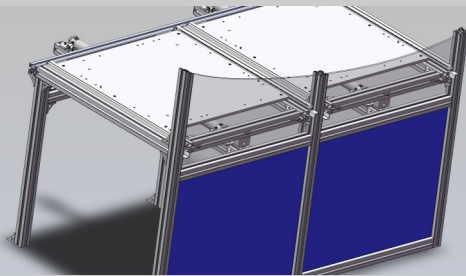

DUAL DRAWERS - MODEL: DRW-2H-14274

Two drawer assembly for part load/unload arranged horizontally side-by-side. Each drawer has 2 positions (opened outside and closed inside the cell). They can be opened automatically on the outside and closes automatically using pneumatic actuators inside the cell. Various controls schemes are available.

- 24"x24" (610x610 mm) tooling plate size 200 lbs (90 kg) load per drawers
- 24 inch (610 mm) opening outside
- Sensors for every position
- Available controls are: none, discrete I/O, ethernet I/P, Profibus, Devicenet

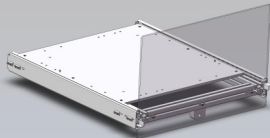

PLASTIC TRAY CONVEYOR - MODEL: CNV-17292-6000

Plastic belt conveyor system for plastic part trays distribution. The trays are metered into position under vision system where parts are identified. Based on requirements, tooling, availability of machines attached to the conveyor trays with parts are fed to next station and pushed left or right into the machine or robotic cell for processing. Finished trays are pushed out back on the conveyor for exit. The method of pushing part trays sideways allows continuous flow of parts to multiple machines/robotic cells attached to conveyor system.

- Overall conveyor length 16 ft (4.9 meters)
- Standard part tray sizes are 17"x22"x3" (430x560x76 mm) and 17"x22"x6" (430x560x152 mm)
- 2 metering stations at entry
- 1 staging station with gate and optional vision system
- 1 side pusher station
- Exit zones
- Sensors for every mechanism and tray presence
- 6" touchscreen interface
- Controls system with PLC, motor controls, and remote I/O system
- Standard interface is Ethernet I/O
- Optional interfaces are Profibus and Devicenet

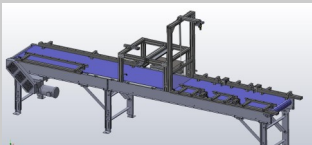
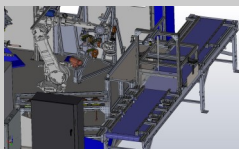
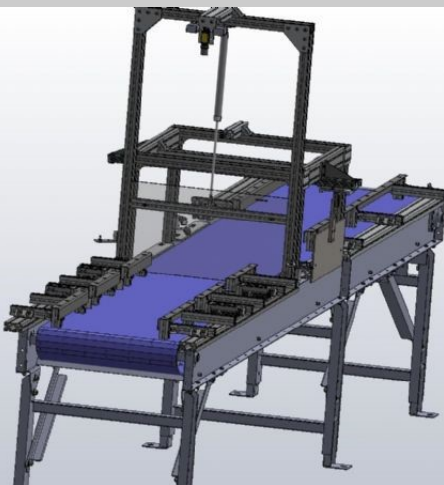

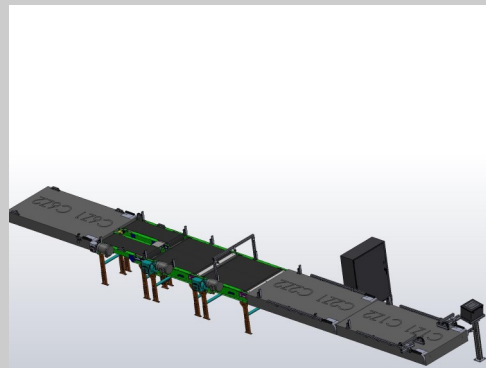

RUBBER CONVEYOR HEAVY PARTS - MODEL: CNV-17287-6100

Rubber conveyor system for large parts made of 6 independently motorized conveyors sections providing total of 9 part staging zones. 3 of the conveyor sections are with 2 part staging zones, 2 sections are single, and 1 section is single split with part lift mechanism in center. One of the zones can be equipped with optional vision system for part identification. Part presence and other sensors are provided at each staging zone. Fully assembled, wired, and programmed for safe part feeding from entry through part pick/drop section to exit.

- Up to 36"x36" (915x915 mm) parts can be transported
- Parts can be up to 200 lbs (90 kg) heavy
- Up to 5 part staging zones before vision inspection
- One staging zones after vision
- One split pick/drop zone with optional part lifter mechanism
- Two staging zones at exit
- Sensors at every zone
- Optional 6" touchscreen interface
- Controls system with PLC, VFD, and remote I/O system
- Standard interface is Ethernet I/O
- Optional interfaces are Profibus and Devicenet.
- Optional safety fence

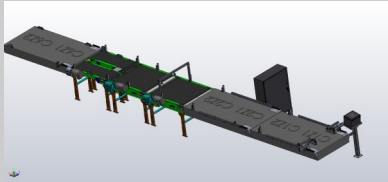
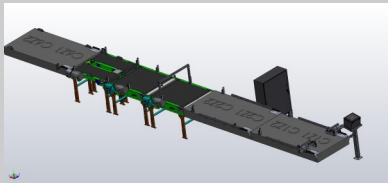

CONVEYOR FOR FEEDING/METERING TRAYS - MODEL: CNV-20130421-000

Conveyor system for feeding/metering standardized part trays in upper section to part handling position, lowering finished tray, and returning it back to operator in the lower section. Trays must follow specific design for size and locating features but can be customized with end user's part fixtures. The conveyor can operate in dry environment or with coolant.

- Overall conveyor size is 1035mm L x 432mm W x 435mm H
- Common mounting plate
- Part trays 320x270 mm (12.59"x10.63")
- Upper conveyor made of 2 tray staging zones and final tray lock zone
- Lower conveyor for feeding trays out has 2 zones
- Elevator mechanism from upper to lower conveyor provides additional tray staging
- Sensors at every zone. Optional 6" touchscreen interface
- Controls system with PLC, VFD, and remote I/O system
- Standard interface is Ethernet I/O
- Optional interfaces are Profibus and Devicenet
- Optional safety fence

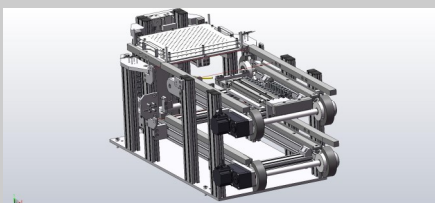
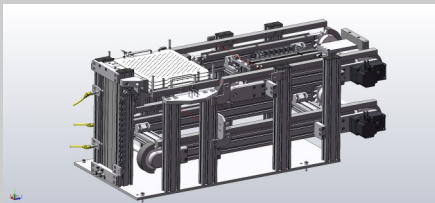
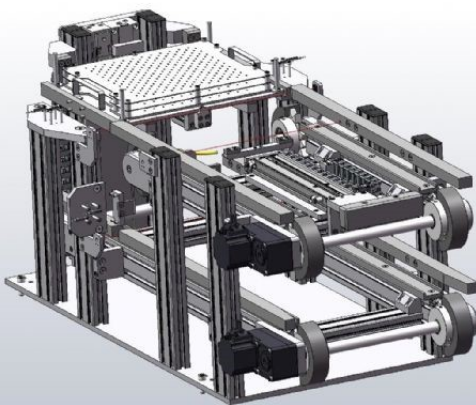

**CONVEYOR FOR FEEDING/METERING TRAYS - MODEL:
CNV-14273-8100-000**

Conveyor system for feeding/metering standardized part trays from entry to part handling positions and to exit. There are 2 staging zones at entry, one locating zone for part picking, one zone for part dropping, and two zone at exit. Trays must follow specific design for size and locating features but can be customized with end user's part fixtures. The conveyor can operate in dry environment or with coolant.

- Overall conveyor size is 2130mm L x 415mm W x 235mm H
- Mounting post included
- Part trays 320x270 mm (12.59"x10.63")
- Entry has 2 tray staging zones
- 1 tray lock zone for part pickup
- 1 tray lock zone for part drop off
- Exit section has 2 zones for tray accumulation
- Sensors at every zone
- Optional 6" touchscreen interface
- Controls system with PLC, VFD, and remote I/O system
- Standard interface is Ethernet I/O
- Optional interfaces are Profibus and Devicenet
- Optional safety fence

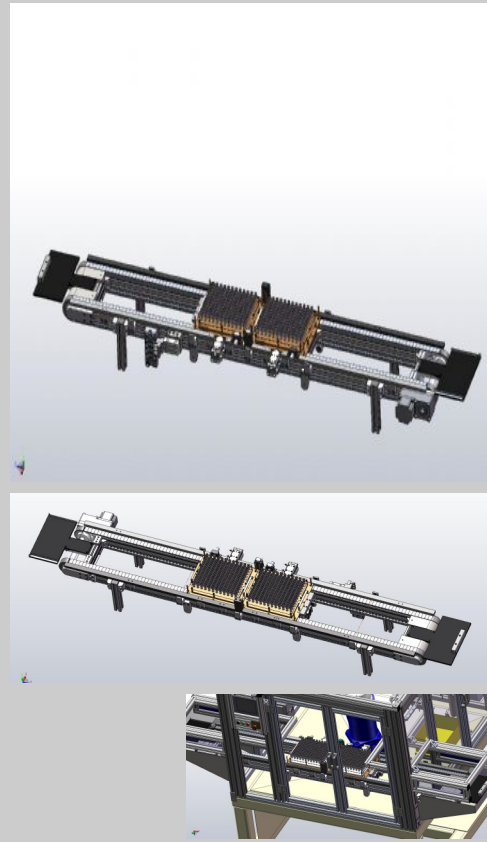

**PART PRESENTATION:
Rotary Tables and Indexers**

**ROTARY POSITIONER WITH PNEUMATIC CHUCK -
MODEL: ROT-CR-12-15000**

Rotary table assembly with pedestal, 3-jaw pneumatic chuck, and wiring/plumbing ready to use. The table can rotate continuously at 12 RPM or stop as programmed when 7th axis of the robot is used as drive motor. Applications include rotating and positioning of IBRs, compressor disks, hubs, housings, gears, etc. Interface for Yaskawa or ABB servo motor are standard. Other interfaces can be designed and supplied.

- Continuous rotation or positioning with servo motor drive
- Payload: 500 lbs (230 kg)
- Table speed with 2000 RPM servo motor drive: 12 RPM
- Optional faster speeds are available
- Repeatability: +/-10 arcsec
- Adapters for Yaskawa and ABB servo motors
- 3-jaw pneumatic chuck mounted on top of rotary table
- Total Rated Grip Force $F @ 100 \text{ psi} [7 \text{ bar}]$: 13345 N [3000 lbs]
- Total Stroke: 34.9 mm [1.38 in]

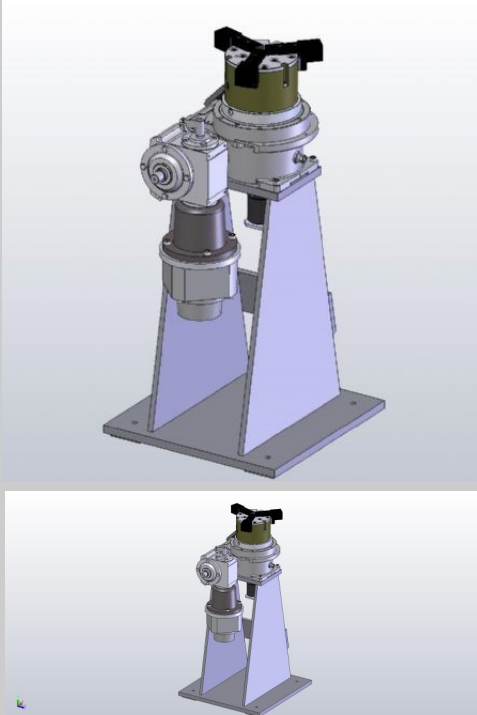

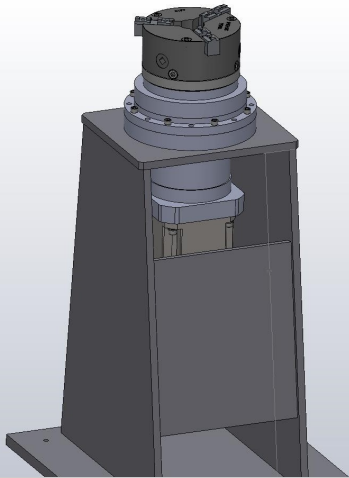

ROTARY POSITIONER WITH MANUAL CHUCK - MODEL: ROT-CR-12-17000

Rotary table assembly with pedestal, 3-jaw Yuasa-style manual chuck, ready to use. The table can rotate continuously at 12 RPM or stop as programmed when 7th axis of the robot is used as drive motor. Applications include rotating and positioning of IBRs, compressor disks, hubs, housings, gears, etc. Interface for Yaskawa or ABB servo motor are standard. Other interfaces can be designed and supplied.

- Continuous rotation or positioning with servo motor drive
- Payload: 500 lbs (230 kg)
- Table speed with 2000 RPM servo motor drive: 12 RPM
- Optional faster speeds are available
- Repeatability: +/-10 arcsec
- Adapters for Yaskawa and ABB servo motors
- 3-jaw Yuasa manual Accu-Chuck with center adjustment mounted on top of rotary table

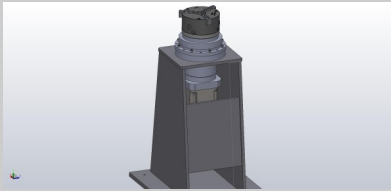

LARGE LOW PROFILE TURNTABLE - MODEL: ROT-CR-16285

Large floor level chain drive rotary table for large heavy parts. Continuous rotation or positioning with servo motor drive system. Clamping brakes provide additional holding force when table top stopped.

- Payload: 5000 lbs (2280 kg) evenly distributed from center
- Table top speed with 3000 RPM motor: 3.7 RPM
- Table height: 3 inches (76 mm)
- Table top diameter: 141 inches (3.58 meters)

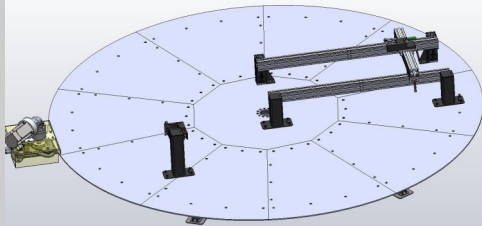

HIGH SPEED PART SPINNER - MODEL: ROT-HS-11257

This is high speed rotary table designed for spinning parts during finishing process. Applications range from buffing, polishing, or sanding of round pieces like kettles, buckets, pots and pans, housings, etc. where spinning part while articulating abrasives against its surfaces yields desired surface finish.

- Payload: 300 lbs (135 kg)
- Table top speed with 3500 RPM motor: 2190 RPM
- Table dimensions: 25.5"Lx15"Wx21"H (650x380x535 mm)
- Table top diameter: 12 inches (305 mm)
- Common mounting base included

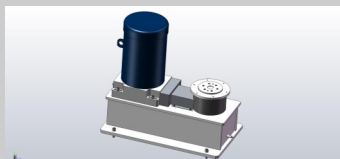
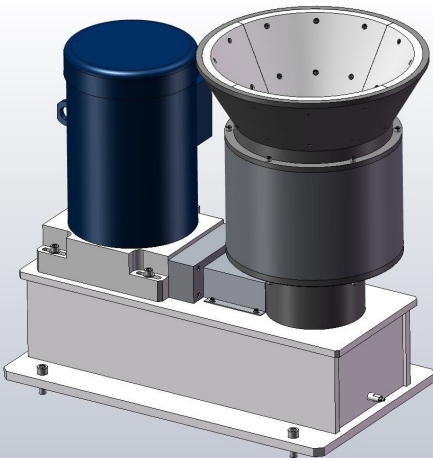

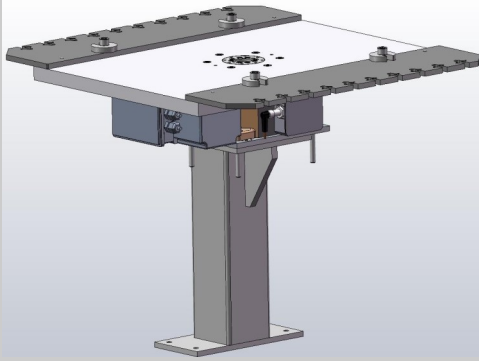

LIGHTER PAYLOAD INDEXER - MODEL: INDX-180D-19305

Two position CAM style indexer (180 degree) with pedestal and top plate. Driven by electric motor with brake.

- Allowable part/fixture load force: 5000 N (1125 lbs)
- Positioning accuracy: +/-30 arcsec
- Top fixture frame dimensions: 63"W x 18"D x 29"H (1600x460x737 mm)
- Height with pedestal: 47" (1194 mm)
- Sensors (PNP): In position, side A, side B

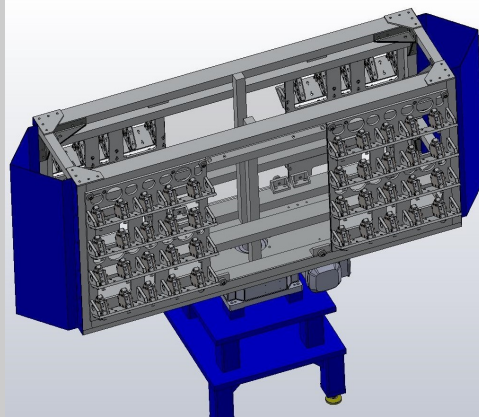

HEAVY PAYLOAD INDEXER - MODEL: INDX-180D-12262

Two position CAM style indexer (180 degree) with pedestal and vertical fixture frame. Driven by electric motor with brake. Fixture frame designed for quick mounting of part load plates/fixtures.

- Allowable part/fixture load force: 5000 N (1125 lbs)
- Positioning accuracy: +/-30 arcsec
- Top fixture frame dimensions: 63"W x 18"D x 29"H (1600x460x737 mm)
- Height with pedestal: 47" (1194 mm)
- Sensors (PNP): In position, side A, side B



INDEXER WITH CUBE FIXTURE FRAME - MODEL: INDX-90D-13267

Four position CAM style indexer (90 degree) with pedestal and vertical 4-sided fixture frame (cube). Driven by electric motor with brake. Fixture frame designed for mounting of customer part load plates/fixtures.

- Payload: 300 lbs (135 kg)
- Table top speed with 3500 RPM motor: 2190 RPM
- Table dimensions: 25.5"Lx15"Wx21"H (650x380x535 mm)
- Table top diameter: 12 inches (305 mm)
- Common mounting base included



INDEXER W/ UTILITIES FEEDTHROUGH - INDX-120D-17291

Three position CAM style indexer (120 degree) with pedestal welded frame and top plate. Driven by electric motor with brake. Top plate designed for quick mounting of part load plates/fixtures. Utilities like I/O network, air, and power fed to the top plate allowing various controls to be mounted on indexer and continuous rotation. Casters and leveling feet are included for easy repositioning.

- Allowable part/fixture load force: 5000 N (1125 lbs)
- Positioning accuracy: +/-30 arcsec
- Top plate diameter: 60" (1524 mm)
- Height with pedestal and casters: 36" (915 mm)
- Sensors (PNP): In position, sides A,B,C
- Utilities fed to top plate: I/O network like Ethernet I/P, Profibus, Devicenet, compressed air, power (24VDC)

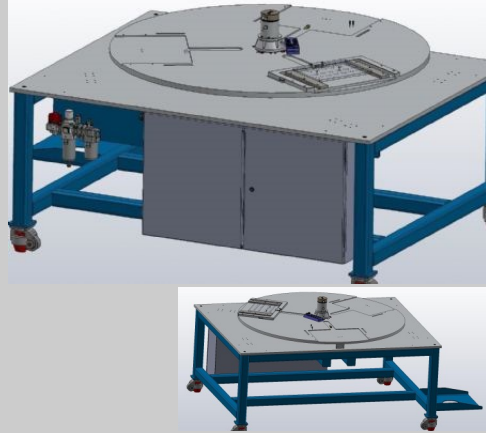

INDEXER W/ UTILITIES FEEDTHROUGH - INDX-90D-17288

Four position CAM style indexer (90 degree) with pedestal welded frame and 4-sided part fixture mounting plates. Driven by electric motor with brake. Top plate designed for quick mounting of part load plates/fixtures. Utilities like I/O network, air, and power fed to the top plate allowing various controls to be mounted on indexer and continuous rotation. Mounting feet are included for easy repositioning.

- Allowable part/fixture load force: 5000 N (1125 lbs)
- Positioning accuracy: +/-30 arcsec
- Top plates structure dimensions: 30" x 30" x 20" (762 x 762 x 508 mm)
- Height with pedestal: 40" (1016 mm)
- Sensors (PNP): In position, sides A,B,C,D
- Utilities fed to top plate: I/O network like Ethernet I/P, Profibus, Devicenet, compressed air, power (24VDC)

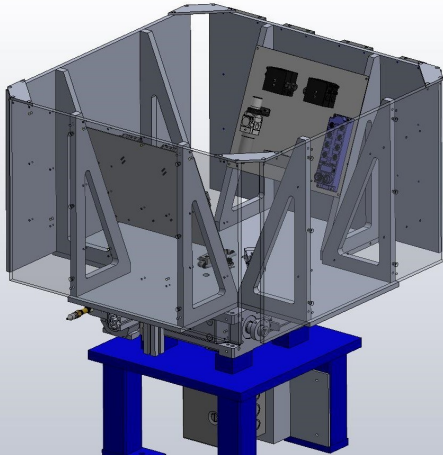

INDEXER WITH SPINDLES - INDX-90D-20121112-01

Four position CAM style indexer (90 degree) with pedestal welded frame and 4 dual part spindle assemblies (SPND-20140226-100). Driven by electric motor with brake. Optionally the indexer may be provided just with top plate structure (no spindles). Utilities like I/O network, air, and power fed to the top plate allowing various controls to be mounted on indexer and continuous rotation. Mounting feet are included for easy repositioning. This indexer can be used in dry and wet applications.

- Allowable part/fixture load force: 5000 N (1125 lbs)
- Positioning accuracy: +/-30 arcsec
- Top plates structure dimensions: 30" x 30" x 20" (762 x 762 x 508 mm)
- Height with pedestal: 40" (1016 mm)
- Sensors (PNP): In position, sides A,B,C,D
- Utilities fed to top plate: I/O network like Ethernet I/P, Profibus, Devicenet, compressed air, power (120/240 VAC)

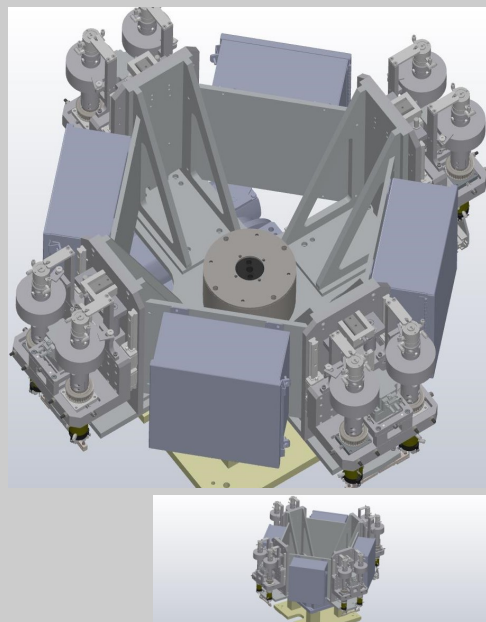

INDX-90D-12-16000 - RECIPROCATING INDEXER

Reciprocating indexer for rotating large parts or stations between 0 and 90 degrees. Actuated by pneumatic cylinder against adjustable stops.

- Payload: 1000 lbs (455 kg) evenly distributed from center
- Index: 0-90 degrees
- Index and holding force: 240 lbs (1067 N)
- Table height: 3.75 inches (95 mm)
- Table top diameter: 22 inches (560 mm)
- Sensors (PNP): at 0 deg, at 90 deg

Belt Grinding and Polishing Stations

BGH-2HP-LC - BELT GRINDING HEAD 2 HP

Belt grinding and polishing head with 2HP AC motor, linear compliance slide, and pneumatic force control built with precision for automated or manual use. Optionally the head can be purchased without compliance slide. The belt head is on common mounting plate. Optional controls include discrete I/O, Ethernet I/P, Profibus, or Devicenet.

- 2HP AC motor driven
- Belt speeds with 3450RPM motor up to 5400 SFPM (surface feet per minute)
- Belts up to 3" (76mm) wide and 72" or 90" (1830 or 2280 mm) long depending on front arm
- Manual belt tracking
- Linear compliance slide with up to 0.75" travel (19mm) and pneumatic force up to 30 lbs (13.5 kg)
- Optional fully plumbed and wired ready for use
- Available controls are: discrete I/O, Ethernet I/P, Profibus, Devicenet
- Front arms with various contact wheels
- Sensors for linear compliance forward/reverse positions and broken/missing belt

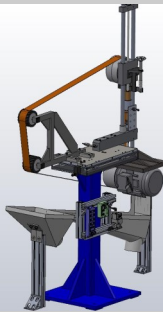
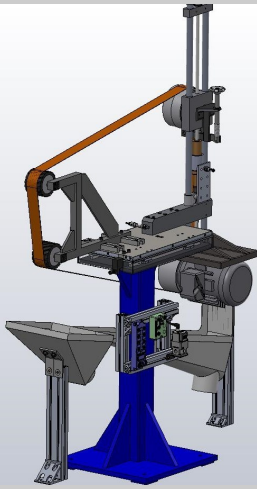

BELT HEAD, 5HP - BGH-5HP-LC-LD

Belt grinding and polishing head with 5HP AC motor, linear compliance slide, and pneumatic force control built with precision for automated or manual use. Optionally the head can be purchased without compliance slide. The belt head is mounted on pedestal. Optional controls include discrete I/O, Ethernet I/P, Profibus, or Devicenet.

- 5HP AC motor driven
- Belt speeds with 3450RPM motor up to 5400 SFPM (surface feet per minute)
- Standard abrasive belts up to 4" (102mm)wide and 132" (3352 mm) long depending on front arm
- Manual belt tracking
- Linear compliance slide with up to 0.75" travel (19mm) and pneumatic force up to 90 lbs (41 kg)
- Optional fully plumbed and wired ready for use
- Available controls are: discrete I/O, Ethernet I/P, Profibus, Devicenet
- Front arms with various contact wheel configurations
- Sensors for linear compliance forward and reverse positions and broken/missing belt
- Optional remote motorized belt tracking

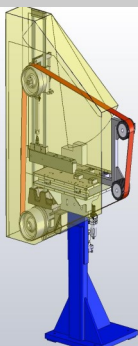
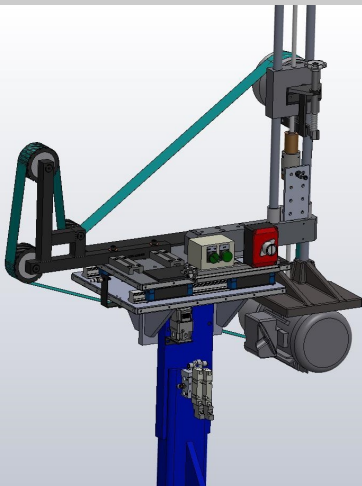

BELT HEAD, 5HP - BGH-5HP-LC-HD

Belt head for heavy grinding with 5HP AC motor, linear compliance slide, and pneumatic force control built with precision for automated or manual use. Optionally the head can be purchased without compliance slide. The belt head is on common mounting plate. Optional controls include discrete I/O, Ethernet I/P, Profibus, or Devicenet.

- 5HP AC motor driven
- Belt speeds with 3450RPM motor up to 5400 SFPM (surface feet per minute)
- Standard abrasive belts up to 4" (102mm)wide and 132" (3352 mm) long depending on front arm
- Manual belt tracking
- Linear compliance slide with up to 0.75" travel (19mm) and pneumatic force up to 90 lbs (41 kg)
- Optional fully plumbed and wired ready for use
- Available controls are: discrete I/O, Ethernet I/P, Profibus, Devicenet
- Front arms with various contact wheel configurations
- Sensors for linear compliance forward and reverse positions and broken/missing belt
- Optional remote motorized belt tracking

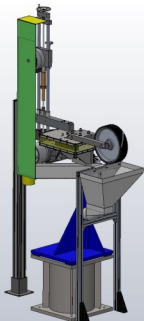
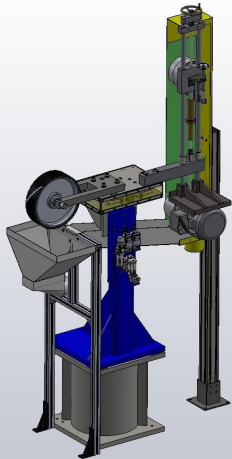

BELT HEAD, 10HP - BGH-10HP-LC

Belt head for heavy grinding with 10HP AC motor, linear compliance slide, and pneumatic force control built with precision for automated or manual use. Optionally the head can be purchased without compliance slide. The belt head is mounted on pedestal. Optional controls include discrete I/O, Ethernet I/P, Profibus, or Devicenet.

- 10HP AC motor driven
- Belt speeds with 3450RPM motor up to 5400 SFPM (surface feet per minute)
- Standard abrasive belts up to 6" (152mm) wide and 132" (3352 mm) long depending on front arm
- Manual belt tracking
- Linear compliance slide with up to 0.75" travel (19mm) and pneumatic force up to 90 lbs (41 kg)
- Optional fully plumbed and wired ready for use
- Available controls are: discrete I/O, Ethernet I/P, Profibus, Devicenet
- Front arms with various contact wheel configurations
- Sensors for linear compliance forward and reverse positions and broken/missing belt
- Optional remote motorized belt tracking

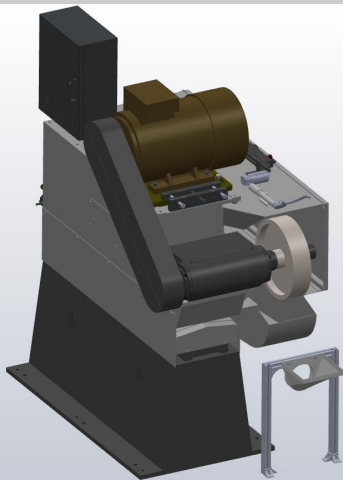

BELT HEAD, 40HP - BGH-40HP-LC

Belt head for heavy and rapid grinding with 40HP AC motor, linear compliance slide, and pneumatic force control built with precision for automated or manual use. Optionally the head can be purchased without compliance slide. The belt head is on heavy duty steel base. Optional controls include discrete I/O, Ethernet I/P, Profibus, or Devicenet.

- 40HP AC motor driving from wheel
- Belt speeds with 3450RPM motor and 18" diameter wheel up to 16000 SFPM (surface feet per minute)
- Standard abrasive belts up to 6" (152mm) wide and 132" (3352 mm) long
- Manual belt tracking
- Linear compliance slide with up to 1" travel (25mm) and pneumatic force up to 350 lbs (160 kg)
- Optional fully plumbed and wired ready for use
- Available controls are: discrete I/O, Ethernet I/P, Profibus, Devicenet
- Various front contact wheels
- Sensors for linear compliance forward and reverse positions and broken/missing belt
- Optional remote motorized belt tracking

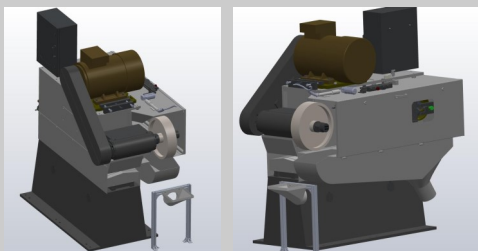

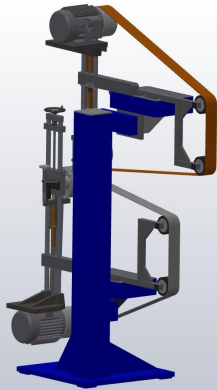
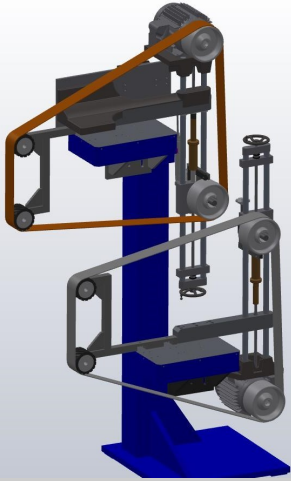
**BELT HEADS, 5HP, OVER/UNDER - BGHX2-5HP-LC**

Two 5HP belt heads (BGH-5HP-LC-HD) mounted one over the other on pedestal. Each belt head is for heavy grinding or polishing with 5HP AC motor, linear compliance slide, and pneumatic force control built with precision for automated use. Optionally the head can be purchased without compliance slide. The belt heads are on common mounting pedestal. Optional controls include discrete I/O, Ethernet I/P, Profibus, or Devicenet.

- Two belt heads in over/under mounting
- 5HP AC motor driven
- Belt speeds with 3450RPM motor up to 5400 SFPM (surface feet per minute)
- Standard abrasive belts up to 4" (102mm) wide and 132" (3352 mm) long depending on front arm
- Manual belt tracking
- Linear compliance slide with up to 0.75" travel (19mm) and pneumatic force up to 90 lbs (41 kg)
- Optional fully plumbed and wired ready for use
- Available controls are: discrete I/O, Ethernet I/P, Profibus, Devicenet
- Front arms with various contact wheel configurations
- Sensors for linear compliance forward and reverse positions and broken/missing belt
- Optional remote motorized belt tracking

Spindle Stations

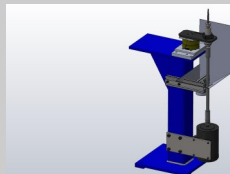
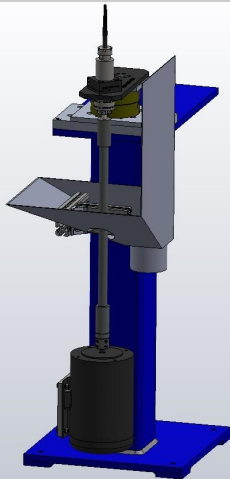
**DRILL/REAMER SPINDLE - SPND-X1-XY-0.5HP**

Single precision spindle with manual collet for 1/2" (50mm) arbors, drill, or reamer bits driven by 1/2HP electric motor. XY lateral compliance with 1" (25mm) travel in all directions allows spindle to float with part features like holes during drilling or reaming operations. Entire assembly comes mounted on a pedestal with dust guards and scoop.

- Power: 1/2HP. Speed range: 0-3450 with VFD
- Compliance travel: +/-1" (+/-25mm) in X and Y plane
- Pneumatically lockable to center position
- Standard manual 1/2" (12.5mm) collet - other sizes available
- Optional fully plumbed and wired ready for use
- Available controls are: discrete I/O, Ethernet I/P, Profibus, Devicenet

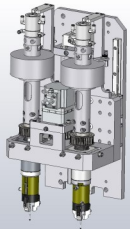
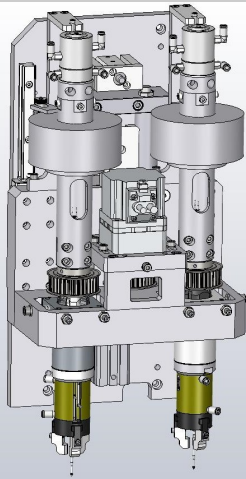

DUAL PART GRIPPING SPINDLE - SPND-20140226-100

Spindle with dual part grippers and continuous reversible rotation with speed control for dry and wet applications. Mounted on linear slide with pneumatic extend/retract motion. Feed-through devices connect electrical sensor signals and compressed air to part grippers thus allowing continuous rotation. Servo motor with hall sensor feedback is used for closed loop speed control.

- Rated torque: 15.9 lbs-in
- Standard speed range: 4-20 RPM with drive
- Pneumatically controlled linear slide travel: 3" (75mm)
- Two 3-jaw grippers with 0.157" (4mm) travel of each jaw
- Max workpiece weight: 1.3 lbs (0.6kg)
- Optional fully plumbed and wired ready for use
- Available controls are: discrete I/O, Ethernet I/P, Profibus, Devicenet
- Sensors for grippers open and close, slide extended and retracted
- Dry or wet applications

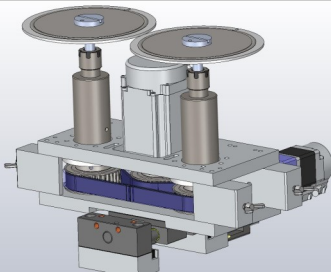
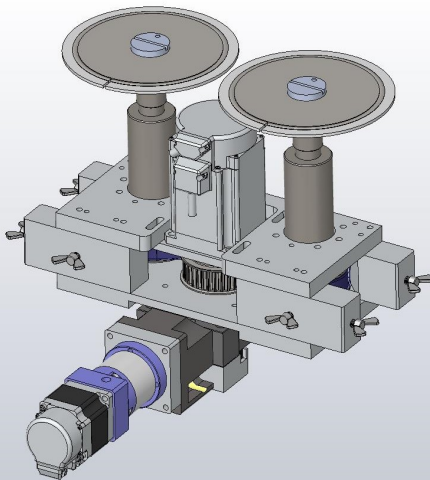

DUAL ABRASIVE SPINDLE - SPND-20121030-001

Dual precision spindles for abrasive wheels mounted on 3/8" or 10mm arbors. This spindle assembly is suitable for operating in wet environment/application. The spindles are driven by electric servo motor with feedback for precise reversible speed control. Entire mechanism can be standalone or mounted on linear ballscrew slide where abrasives can be positioned for process and retracted when done. Z3D supplies Allen Bradley servo motors for slide positioning but customer motor choice can also be accommodated.

- Rated torque: 11.5 lbs-in (1.3 Nm)
- Standard speed range: 0-5000 RPM with drive
- Ballscrew linear slide travel: 0.75" (19mm)
- Each spindle with manual collet
- Standard collet sizes are 3/8" or 10mm
- Other collet sizes available
- Optional fully plumbed and wired ready for use
- Available controls are: discrete I/O, Ethernet I/P, Profibus, Devicenet
- Sensors for slide home and over travel limits
- Dry or wet applications

FOUR SPINDLE ASSEMBLY - SPND-20140505-200

Four abrasive wheel spindles assembly made of 2 independent dual spindles SPND-20121030-001 mounted opposite to each other. Two parts at the same time can be positioned between the dual spindles and processed by rotating the parts and extending abrasive spindles from both sides. Each dual spindle is precision made for abrasive wheels mounted on 3/8" or 10mm arbors.

This spindle assembly is suitable for operating in wet environment/application. The spindles are driven by electric servo motor with feedback for precise reversible speed control. Entire mechanism can be standalone or mounted on linear ballscrew slide where abrasives can be positioned for process and retracted when done. Z3D supplies Allen Bradley servo motors for slide positioning but customer motor choice can also be accommodated.

- Each dual spindle specifications are as follows
- Rated torque: 11.5 lbs-in (1.3 Nm)
- Standard speed range: 0-5000 RPM with drive
- Ballscrew linear slide travel: 0.75" (19mm)
- Each spindle with manual collet
- Standard collet sizes are 3/8" or 10mm
- Other collet sizes available
- Optional fully plumbed and wired ready for use
- Available controls are: discrete I/O, Ethernet I/P, Profibus, Devicenet
- Sensors for slide home and overtravel limits
- Dry or wet applications

SIX SPINDLE ASSEMBLY - SPND-14273-8200-000

Six spindle station with manual collets driven by single servo motor designed and built originally to power 6 abrasive brushes for deburring of up to 6 parts at once. Servo motor with drive provides precise reversible speed control of the spindles. Included in the assembly are sensors for abrasive media arbors and coolant spray nozzles at each spindle. There are no compliance devices. Spindle comes with mounting pedestal.

- Rated torque: 11.5 lbs-in (1.3 Nm)
- Standard speed range: 0-1250 RPM with drive
- Each spindle with manual collet
- Standard collet sizes are 1/8-3/8" or 4-10mm
- Optional fully plumbed and wired ready for use
- Available controls are: discrete I/O, Ethernet I/P, Profibus, Devicenet
- Sensors for abrasive arbor present at each spindle
- Coolant spray nozzle at each spindle
- Dry or wet applications.

Wheel and Cutoff Heads

DUAL WHEEL HEAD - WHL-5-10HP-X2-LC

Dual shaft heavy duty wheel head driven by 5HP AC motor. Abrasive wheels like grinding, polishing, or buffing can be mounted on both ends of the shaft using flanges and standard hardware. Entire wheel assembly is mounted on linear compliance slide which moves during process while exerting force which can be controlled from a programmable controller. This allows easier part programming where finishing process is done by pushing part into the force controlled linear slide travel. The head comes with mounting pedestal and can optionally be with fully connected controls interfacing to customer's system via discrete I/O, Ethernet I/P, Profibus, or Devicenet.

- Power rating: 5, 7.5, or 10 HP
- Speed range: 500-3000 RPM with VFD
- Dual shaft sizes range: 1"-2" diameter (25-50mm)
- Linear compliance slide with heavy duty profile rails
- Linear travel: adjustable up to 1" (25mm)
- Compliance force range: 0-90 lbs (0-40 kg)
- Optional fully plumbed and wired ready for use
- Available controls are: discrete I/O, Ethernet I/P, Profibus, Devicenet
- Standard sensors: compliance slide extended and retracted
- Optional wheel wear (size) measuring sensors
- Wheel guards and dust scoops included

SINGLE WHEEL HEAD - WHL-5HP-X1-MC-LC

Lighter duty wheel head with wheel arbor/shaft attached directly to 5HP AC motor. Abrasive wheels like grinding, polishing, or buffing can be mounted on that arbor using flanges and standard hardware. Entire wheel assembly is mounted on linear compliance slide which moves during process while exerting force which can be controlled from a programmable controller. This allows easier part programming where finishing process is done by pushing part into the force controlled linear slide travel. The head comes with mounting pedestal and can optionally be with fully connected controls interfacing to customer's system via discrete I/O, Ethernet I/P, Profibus, or Devicenet.

- Power rating: 5HP
- Speed range: 500-3450 RPM with VFD
- Arbor shaft sizes range: 1"-2" diameter (25-50mm)
- Linear compliance slide with heavy duty profile rails
- Linear travel: adjustable up to 1" (25mm)
- Compliance force range: 0-90 lbs (0-40 kg)
- Optional fully plumbed and wired ready for use
- Available controls are: discrete I/O, Ethernet I/P, Profibus, Devicenet
- Standard sensors: compliance slide extended and retracted
- Optional wheel wear (size) measuring sensors
- Wheel guards included
- Dust scoops optional

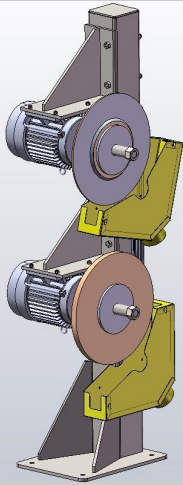

TWO SINGLE WHEEL HEADS ASSEMBLY - WHL-ASSY2-5HP-MC-LC

Two single wheel heads (WHL-5HP-X1-MC-LC) assembly mounted in over/under configuration on single stand. Each wheel head is lighter duty with wheel arbor/shaft attached directly to 5HP AC motor. Abrasive wheels like grinding, polishing, or buffing can be mounted on that arbor using flanges and standard hardware. Entire wheel assembly is mounted on linear compliance slide which moves during process while exerting force which can be controlled from a programmable controller. This allows easier part programming where finishing process is done by pushing part into the force controlled linear slide travel. The head comes with mounting pedestal and can optionally be with fully connected controls interfacing to customer's system via discrete I/O, Ethernet I/P, Profibus, or Devicenet.

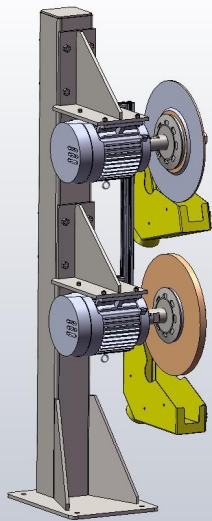

- Specifications for each wheel head
- Power rating: 5HP
- Speed range: 500-3450 RPM with VFD
- Arbor shaft sizes range: 1"-2" diameter (25-50mm)
- Linear compliance slide with heavy duty profile rails
- Linear travel: adjustable up to 1" (25mm)
- Compliance force range: 0-90 lbs (0-40 kg)
- Optional fully plumbed and wired ready for use
- Available controls are: discrete I/O, Ethernet I/P, Profibus, Devicenet
- Standard sensors: compliance slide extended and retracted
- Optional wheel wear (size) measuring sensors
- Wheel guards included
- Dust scoops optional

FOUR WHEEL STATION - WHL-7.5HP-X4-LC

Four wheel stations arranged with 2 dual shaft heavy duty wheel heads one over the other. Each dual shaft wheel head is driven by 7.5 HP AC motors. Abrasive wheels like grinding, polishing, or buffing can be mounted on both ends of the shaft using flanges and standard hardware. Entire wheel assembly is mounted pedestal with guards and dust scoops. The wheels are stationary without any compliance devices. The entire station can optionally be with fully connected controls interfacing to customer's system via discrete I/O, Ethernet I/P, Profibus, or Devicenet.

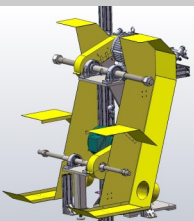
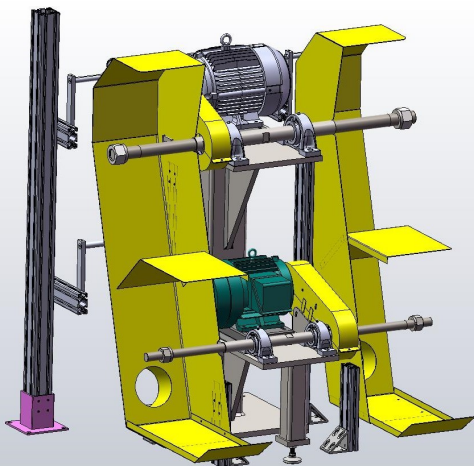

- Power rating: 7.5 HP
- Speed range: 500-3000 RPM with VFDs
- Dual shaft sizes range: 1"-2" diameter (25-50mm)
- Optional fully plumbed and wired ready for use
- Available controls are: discrete I/O, Ethernet I/P, Profibus, Devicenet
- Optional wheel wear (size) measuring sensors
- Wheel guards and dust scoops included
- Compound application system (solid or liquid) optional for buffing applications

DUAL WHEEL HEAD, 60HP - WHL-60HP-X2-LC

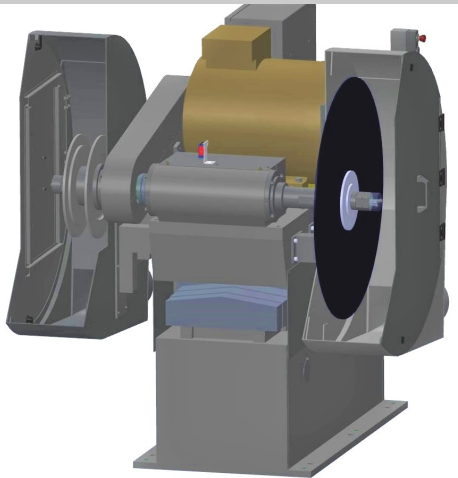

Dual shaft heavy duty grinding and cutoff wheel head driven by 60 HP AC motor. Abrasive wheels like grinding or cutoff can be mounted on both ends of the shaft using flanges and standard hardware. Entire wheel assembly is mounted on linear compliance slide which moves during process while exerting force which can be controlled from a programmable controller. This allows easier part programming where finishing process is done by pushing part into the force controlled linear slide travel. The head comes with mounting pedestal and can optionally be with fully connected controls interfacing to customer's system via discrete I/O, Ethernet I/P, Profibus, or Devicenet.

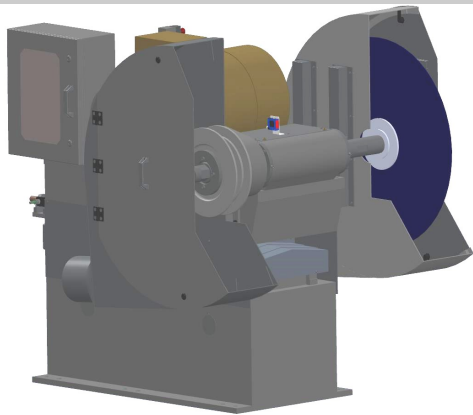

- Power rating: 60 HP
- Speed range: 500-3500 RPM with VFD
- Dual shaft sizes: 2.75" diameter (70mm)
- Wheel diameter up to 36" (915 mm)
- Linear compliance slide with heavy duty profile rails
- Linear travel: adjustable up to 2" (50mm)
- Compliance force range: 0-350 lbs (0-160 kg)
- Optional fully plumbed and wired ready for use
- Available controls are: discrete I/O, Ethernet I/P, Profibus, Devicenet
- Standard sensors: compliance slide extended and retracted
- Optional wheel wear (size) measuring sensors
- Wheel guards and dust scoops included

SINGLE CUTOFF WHEEL CHOP-SAW - WHL-CUT-60HP-CHOP

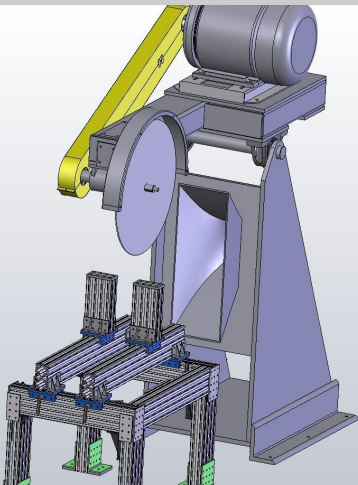

Chop-saw style (pivoting) cutoff head driven by 60 HP AC motor. The cutoff wheel is driven down (pivoted) by a servo linear actuator mounted in the back of the pivot platform. The actuator motor can be linked as auxiliary axis to a robot system or be controlled from another programmable device. Having the saw travel fully controlled from a robot system allows for coordinated motion of the saw with the robotic arm generally holding the part being cut. Guards and dust scoops are included.

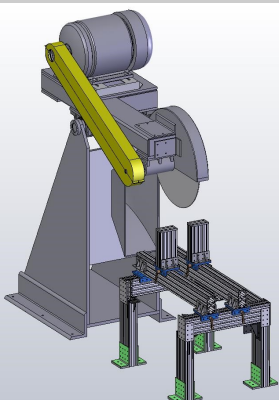

- Power rating: 60 HP
- Speed range: 500-3500 RPM with VFD
- Shaft sizes: 2.75" diameter (70mm)
- Wheel diameter up to 36" (915 mm)
- Wheel travel when pivoting: programmable up to 33" (840 mm)
- Wheel speed up to 10 mm/sec
- Maximum force of wheel on part: 350 lbs (160 kg)
- Optional fully plumbed and wired ready for use
- Available controls are: discrete I/O, Ethernet I/P, Profibus, Devicenet
- Standard sensors: wheel pivot overtravel limits
- Optional wheel wear (size) measuring sensors
- Wheel guards and dust scoops included

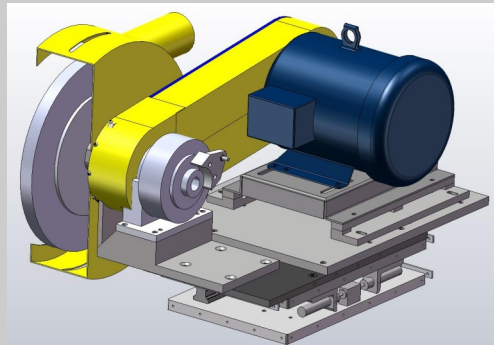
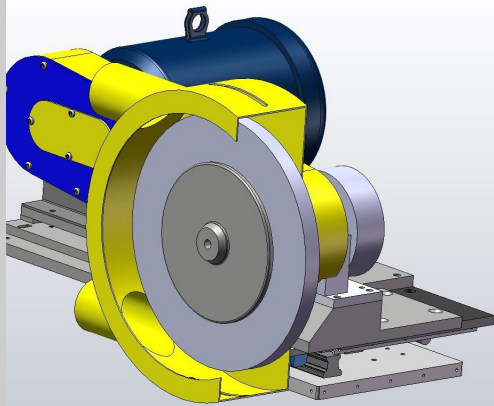

SINGLE WHEEL HEAD WITH AUTO COLLET - WHL-5-10HP-X1-AC-LC

Single wheel head with pneumatically operated collet for automated change of abrasive like finishing, grinding, cutoff, brush, or buff wheels. The head spindle is driven with 5 HP AC motor. Standard collet of 1" (25mm) is opened and closed with compressed air which allows automatic or quick change-over of abrasive wheels and other media mounted on 1" diameter arbors.

Entire wheel assembly is mounted on linear compliance slide which moves during process while exerting force which can be controlled from a programmable controller. This allows easier part programming where finishing process is done by pushing part into the force controlled linear slide travel. The head comes with mounting pedestal and can optionally be with fully connected controls interfacing to customer's system via discrete I/O, Ethernet I/P, Profibus, or Devicenet.

- Application examples: polishing, grinding, cutoff, brushing, buffing
- Power rating: 5, 7.5 or 10 HP
- Speed range: 500-2000 RPM with VFD
- Standard collet size: 1" (25mm)
- Standard abrasive arbors are available
- Abrasive wheel diameter up to 16" (406 mm)
- Linear compliance slide with heavy duty profile rails
- Linear travel: adjustable up to 1" (25mm)
- Compliance force range: 0-90 lbs (0-40 kg)
- Optional fully plumbed and wired ready for use
- Available controls are: discrete I/O, Ethernet I/P, Profibus, Devicenet
- Standard sensors: compliance slide extended and retracted
- Optional wheel wear (size) measuring sensors
- Wheel guards and dust scoops included

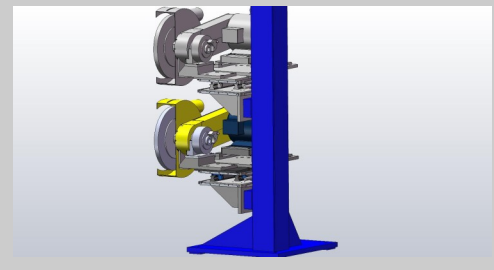
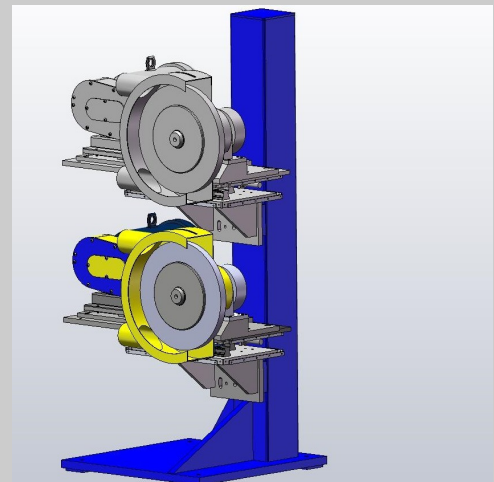

ASSEMBLY OF 2 SPINDLES WITH AUTO COLLET - WHL-ASSY2-5-10HP-AC-LC

Two single wheel heads with auto collet (WHL-5-10HP-X1-AC-LC) assembly mounted in over/under configuration on single stand.

- Application examples: polishing, grinding, cutoff, brushing, buffing
- Power rating: 5, 7.5 or 10 HP
- Speed range: 500-2000 RPM with VFD
- Standard collet size: 1" (25mm)
- Standard abrasive arbors are available
- Abrasive wheel diameter up to 16" (406 mm)
- Linear compliance slide with heavy duty profile rails
- Linear travel: adjustable up to 1" (25mm)
- Compliance force range: 0-90 lbs (0-40 kg)
- Optional fully plumbed and wired ready for use
- Available controls are: discrete I/O, Ethernet I/P, Profibus, Devicenet
- Standard sensors: compliance slide extended and retracted
- Optional wheel wear (size) measuring sensors
- Wheel guards and dust scoops included

Tool Magazine and Docking Nests

LARGE TOOL MAGAZINE - MAG-15282-4000-NN

Large tool magazine capable of storing up to 21 tool assemblies (depending on size). Operator can have access to it via interlocked slider doors facing outside robotic cell enclosure and robot enters it from the inside by opening pneumatically operated bi-fold doors. Both outside and inside entries are protected with safety devices which can be integrated into the machine safety system. There are many styles of tool docking nests available from 45 degree leaning to abrasive arbor nests. All of them are fitted with tool present sensors. Entire tool magazine can optionally be with fully connected controls interfacing to customer's system via discrete I/O, Ethernet I/P, Profibus, or Devicenet.

- Overall size: 88" x 29" x 67" (2235 x 737 x 1702 mm)
- Double slider doors outside the cell
- Double bi-fold doors inside the cell
- Bi-fold doors opened and closed pneumatically
- Up to 3 levels of docking nests
- Safety interlocks for all doors
- Status sensors for bi-fold doors
- Optional docking nests with presence sensors
- Optional fully plumbed and wired ready for use
- Available controls are: discrete I/O, Ethernet I/P, Profibus, Devicenet

SMALL TOOL MAGAZINE - MAG-11256-4000-NN

Small tool magazine capable of storing up to 12 tool assemblies (depending on size). Operator can have access to it via interlocked slider doors facing outside robotic cell enclosure and robot enters it from the inside by opening pneumatically operated hinged doors. Optional up/down electric curtain as inside entry. Both outside and inside entries are protected with safety devices which can be integrated into the machine safety system. There are many styles of tool docking nests available from 45 degree leaning to abrasive arbor nests. All of them are fitted with tool present sensors. Entire tool magazine can optionally be with fully connected controls interfacing to customer's system via discrete I/O, Ethernet I/P, Profibus, or Devicenet.

- Overall size: 44" x 24" x 67" (1118 x 610 x 1702 mm)
- Double slider doors outside the cell
- Double hinged doors inside the cell
- Hinged doors opened and closed pneumatically
- Optional electric up/down curtain as inside entry door
- Up to 3 levels of docking nests
- Safety interlocks for all doors
- Status sensors for both hinged doors
- Optional docking nests with presence sensors
- Optional fully plumbed and wired ready for use
- Available controls are: discrete I/O, Ethernet I/P, Profibus, Devicenet.

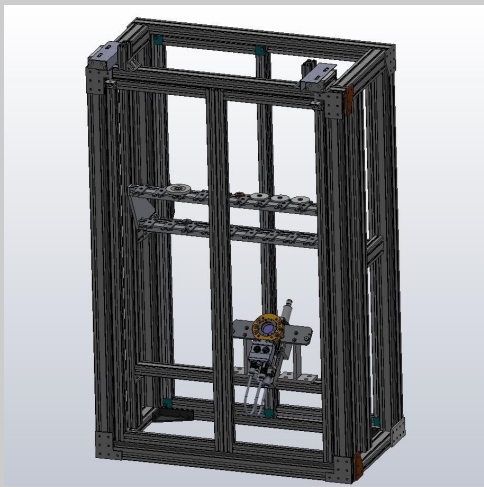
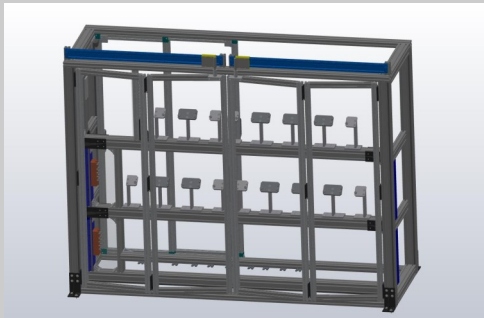
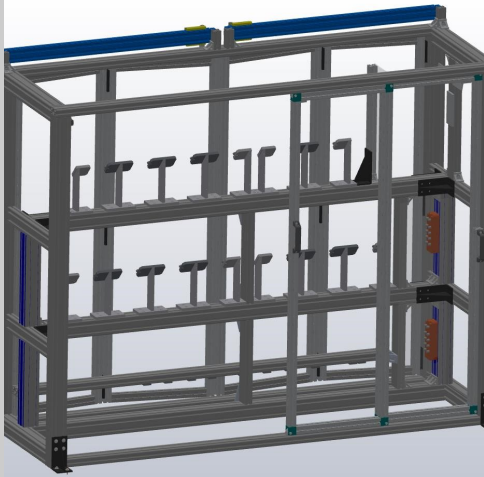

Tool Magazine and Docking Nests

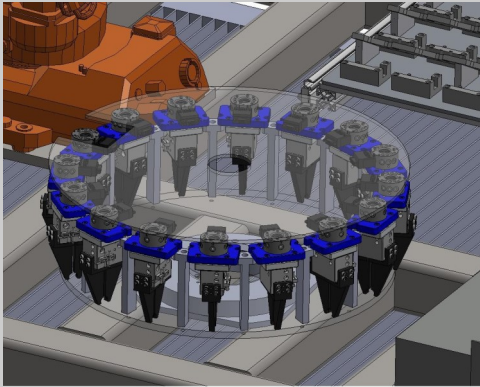

REVOLVER-STYLE ROTARY TOOL MAGAZINE - MAG-17997-4000

Rotary revolver-style tool magazine. Capacity is dependent on tool or gripper size. The magazine indexes desired tool into pick position as programmed in the machine controller. Position sensors monitor magazine and tool location. All controls are fed to the magazine top plate allowing continuous indexing. Single tool pick and drop position makes programming easy.

- Magazine version to store any of Z3D's small and medium size tools like GRP-RP17-TC or GRP-RP18-TC
- Size depends on version and ranges 24" (610 mm) diameter to 48" (1220 mm)
- Capacity: 6 docking nests to 16
- Electric indexer with brake
- Standard sensors (PNP): position number, index complete, tool present
- Optional automatic dust cover at tool pick/drop position
- Optional fully plumbed and wired ready for use
- Available controls are: discrete I/O, Ethernet I/P, Profibus, Devicenet.

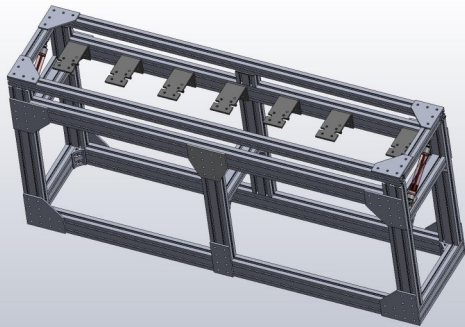

SMALL TOOL MAGAZINE WITH LID COVER - MAG-17292-4000-6

Small tool magazine capable of storing up to 12 tool assemblies (depending on size). Operator has no access to it from outside robotic cell enclosure and robot enters it from the inside by opening pneumatically operated hinged lid fitted with sensors. There are many styles of tool docking nests available from flat small and large to abrasive arbor nests. All of them are fitted with tool present sensors. Entire tool magazine can optionally be with fully connected controls interfacing to customer's system via discrete I/O, Ethernet I/P, Profibus, or Devicenet.

- Overall size: 62" x 15.5" x 29.625" (1575 x 394 x 752 mm)
- Hinged top lid opened and closed pneumatically
- One row of docking nests
- Status sensors for the lid
- Optional docking nests with presence sensors
- Optional fully plumbed and wired ready for use
- Available controls are: discrete I/O, Ethernet I/P, Profibus, Devicenet.

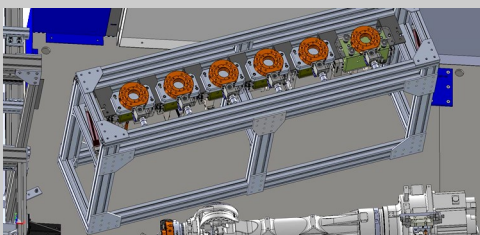

Tool Magazine and Docking Nests

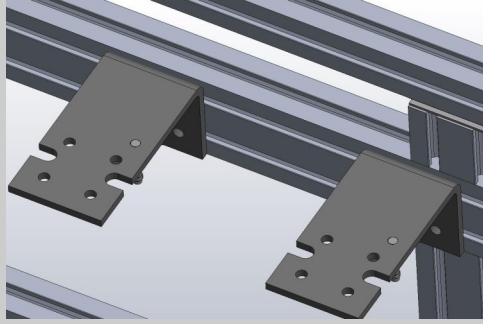

GRIPPER/TOOL DOCKING NEST - NEST-17292-4000-004

Docking nest for smaller and medium gripper assemblies with locating pin holes and sensors. These nests can be used with any of Z3D's tool magazines. Grippers like GRP-RP18-TC, GRP-RP19-TC, GRP-RPC-TC can be docked in these nests.

- Horizontal tool orientation
- Used in any of Z3D's tool magazines
- Attachments for standard slotted aluminum extrusion
- Tool locating holes
- Tool presence sensor

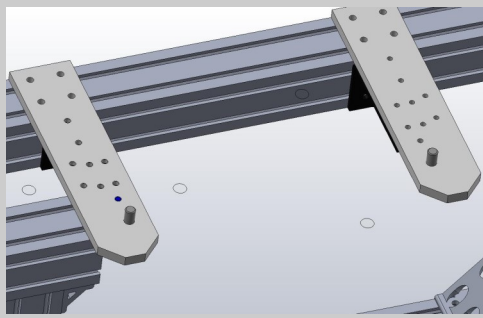

GRIPPER/TOOL DOCKING NEST - NEST-18297-4000-007

Docking nest for large gripper assemblies with locating pin holes and sensors. These nests can be used with any of Z3D's tool magazines. Grippers like GRP-18297-4001 can be docked in these nests.

- Horizontal tool orientation
- Used in any of Z3D's tool magazines
- Attachments for standard slotted aluminum extrusion
- Tool locating holes
- Tool presence sensor.

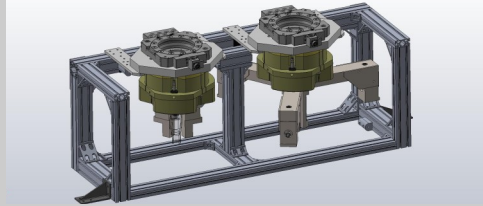

TOOL ASSEMBLY DOCKING NEST - NEST-08162018-00

Tool docking nest with 45 degree leaning tool holding surface. Angled nest surface allows tools to be arranged in vertical rows with robot having clear access to them. Z3D tool assemblies like GRP-RP17-TC, BGT001-13800AR, SP00AC-SR12000, SPD-18298-4000, etc. can be docked in these nests. Locating and tool capturing pins are included as well as tool presence sensor.

- 45 degree tool orientation
- Used in any of Z3D's tool magazines
- Attachments for standard slotted aluminum extrusion
- Tool locating and capturing pins
- Tool presence sensor.

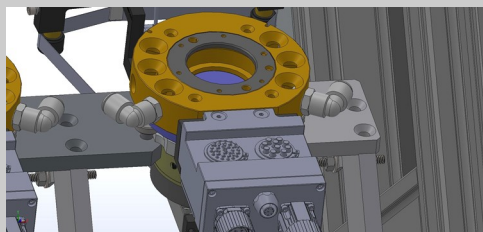

Tool Magazine and Docking Nests

ARBOR DOCKING NEST - NEST-32-11200

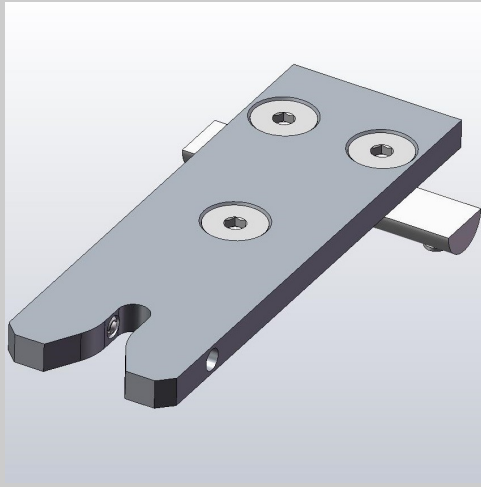

Docking nests for 1/4" (6mm) arbors with abrasives or other tools like drills or reamers. Spring loaded plungers are used for capturing and locating of the arbor. Presence sensor is included.

- Nest in horizontal orientation allows arbors to be vertical
- Used in any of Z3D's tool magazines
- Attachments for standard slotted aluminum extrusion
- Arbor locating and capturing plungers
- Arbor presence sensor

ARBOR TAPER DOCKING NEST - NEST-18298-3001

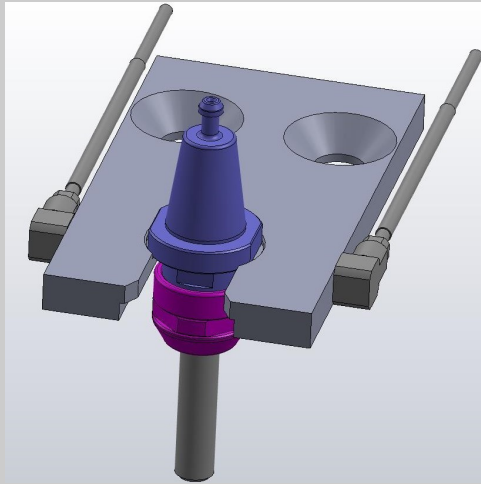

Docking nests for abrasives or tools mounted in NSK QC5-K tapered holders. The nest can be used in any of Z3D's tool magazines. Holder presence sensor is included.

- Nest in horizontal orientation allows taper holders to be vertical
- Used in any of Z3D's tool magazines
- Attaches to standard slotted aluminum extrusion
- Arbor locating and capturing pocket
- Holder/arbor presence sensor

ARBOR DOCKING NEST - NEST-16285-4000-005

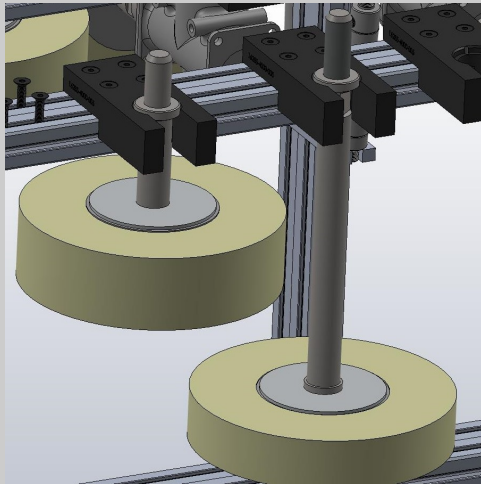

Docking nests for 1" (25mm) arbors with abrasives or other tools like disks, buffs, or brushes. The nests can be used with any of Z3D's tool magazines. Presence sensor is included.

- Nest in horizontal orientation allows taper holders to be vertical
- Used in any of Z3D's tool magazines
- Attaches to standard slotted aluminum extrusion
- Arbor locating and capturing pocket
- Holder/arbor presence sensor

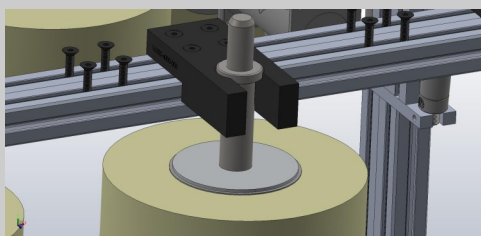

END OF ARM: Tools

Z3D BELT POLISHER- MODEL: BGT001-13800AR

Belt Tool is a precision tool assembly with fixed front contact wheel designed to be mounted to a tool changer or directly to a robotic arm. It can accommodate precision made TCA Tooling or standard Dynabrade style arms as well as custom attachments

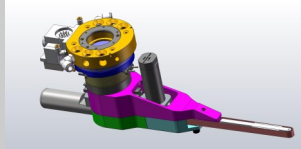
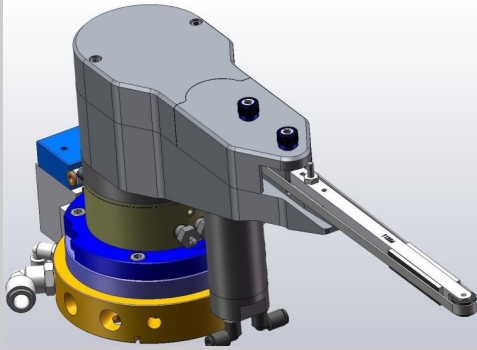

- Powered by reversing air motor with top speed of 13,800 RPM
- Accepts belts of up to ½ inch wide and 24 inch long (depending on the front arm)
- Belt tension easily released for belt change
- Broken or missing belt sensor
- Rotation sensor
- Belt stretch take –up in the back of the tool
- Fixed belt guide eliminates the need for tracking adjustments

SERVO DRIVER SPINDLE - SP00AC-SR12000-RC-TC71

Spindle tool with closed loop servo driven pneumatically activated collet which allows for automatic media change. The tool can be equipped with 1/8" or 1/4" collet and combined with media staging nests has the capability to automatically change worn wheels, brushes, deburring bits and other finishing media. Rotary compliance allows easier programming and settings of force to exert on the part.

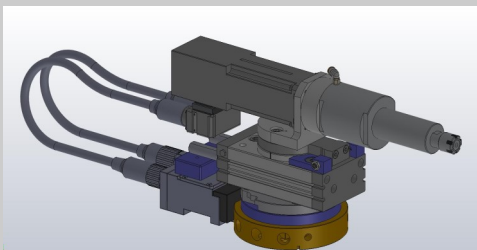
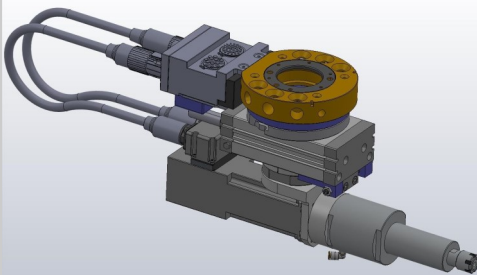

- Electronic speed control from 0 to 12,000 RPM
- Constant torque of 1.3 Nm within the entire speed range
- Closed loop brushless servo motor
- Accommodates brushes, buffs, finishing wheels, cut-off wheels, deburring bits, drill bits, or any other media equipped with either 1/8" or 1/4" shanks
- Air activated collet
- Speed feedback through the servo drive
- Torque feedback through the servo drive
- Separate process parameters for each wheel set through robot program or HMI. Pneumatic rotary compliance with sensors
- Tool change adapter
- Wired and plumbed to tool adapter for mating with robot side tool changer

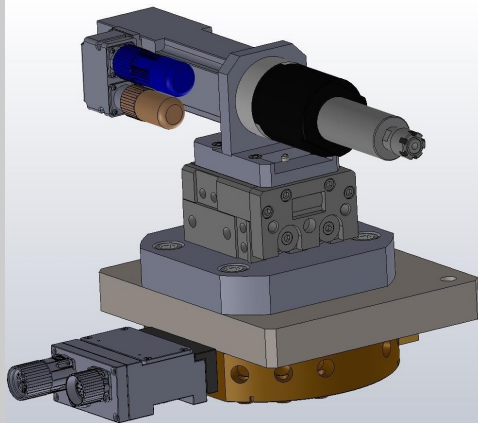

SERVO DRIVER SPINDLE - SPD-17287-4006

Spindle tool with closed loop servo driven pneumatically activated collet which allows for automatic media change. The tool can be equipped with 1/2" (12.5mm) collet and combined with media staging nests has the capability to automatically change worn wheels, brushes, deburring bits and other finishing media. Linear compliance allows easier programming and settings of force to exert on the part.

- Electronic speed control from 0 to 3000 RPM
- Constant torque of 4.9 Nm within the entire speed range
- Closed loop brushless servo motor
- Accommodates brushes, buffs, finishing wheels, cut-off wheels, deburring bits, drill bits, or any other media equipped with 1/2" shanks
- Air activated collet
- Speed feedback through the servo drive
- Torque feedback through the servo drive
- Separate process parameters for each wheel set through robot program or HMI
- Pneumatic rotary compliance with sensors
- Tool change adapter
- Wired and plumbed to tool adapter for mating with robot side tool changer

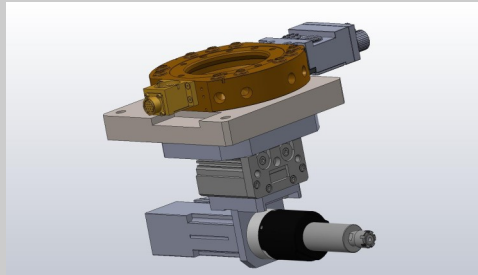

ELECTRIC SPINDLE - SPD-18298-4000

Spindle tool with NSK closed loop servo driven pneumatically activated collet which allows for automatic media change. The tool is equipped with collet for QC5-K tapered holders and combined with media staging nests has the capability to automatically change worn wheels, brushes, deburring bits and other finishing media. Rotary compliance allows easier programming and settings of force to exert on the part.

- Electronic speed control from 0 to 20,000 RPM
- Constant torque of 1.0 Nm within the entire speed range
- Closed loop brushless servo motor with air cooling
- Accommodates brushes, buffs, finishing wheels, cut-off wheels, deburring bits, drill bits, or any other media mounted in QC5-K holders
- Air activated collet
- Speed feedback through the servo drive
- Torque feedback through the servo drive
- Separate process parameters for each wheel set through robot program or HMI. Pneumatic rotary compliance with sensors
- Tool change adapter
- Wired and plumbed to tool adapter for mating with robot side tool changer

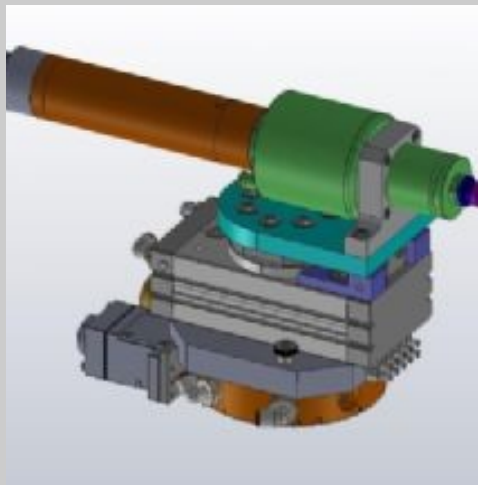

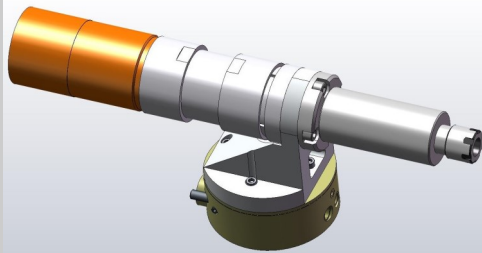

AIR DRIVEN SPINDLES - SPD-20100902-100

Spindle tool with air motor driven pneumatically activated collet which allows for automatic media change. The tool can be equipped with 1/8" or 1/4" collet and combined with media staging nests has the capability to automatically change worn wheels, brushes, deburring bits and other finishing media. Rotary compliance allows easier programming and settings of force to exert on the part.

- Tool models with speeds ranging from 420 to 20,000 RPM
- Torque values ranging from 0.85 Nm to 33.6 Nm depending on the model
- Industrial reversible air motor
- Accommodates brushes, buffs, finishing wheels, cut-off wheels, deburring bits, drill bits, or any other media equipped with either 1/8" or 1/4" shanks.
- Air activated collet
- Options for fully automatic systems
- Separate process parameters for each wheel set through robot program or HMI
- Pneumatic rotary compliance with sensors
- Tool change adapter
- Wired and plumbed to tool adapter for mating with robot side tool changer

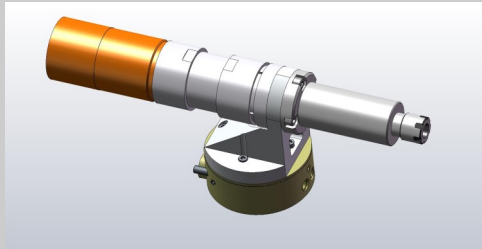

RIGHT ANGLE GRINDER - GRIND-19303-4000

Right angle electric grinder tool with pneumatic pivot compliance. Electric grinder rated at 3HP and 6000 RPM. Addition of air purge keeps the grinder clean from dust and debris extending its life. The compliance allows setting of force exerted by the grinder and provides tool float which simplifies programming and avoid crashes due to variance in grinding surfaces. Optional distance laser sensor and blowoff nozzle.

- Power: 3HP
- Speed: constant at 6000 RPM
- Operating voltage 120 or 220 VAC 1-phase
- Abrasive disks up to 10" (254 mm) diameter
- Compliance travel: 1/2" (12.5 mm)
- Compliance maximum force: 90 lbs (40 kg)
- Air blowoff nozzle
- Mounting plates for standard robot flanges
- Optional distance laser sensor with dust cover

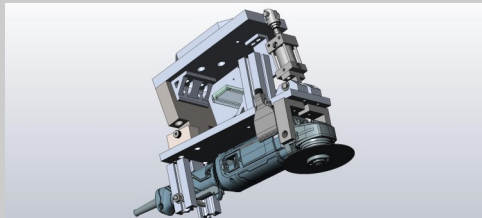
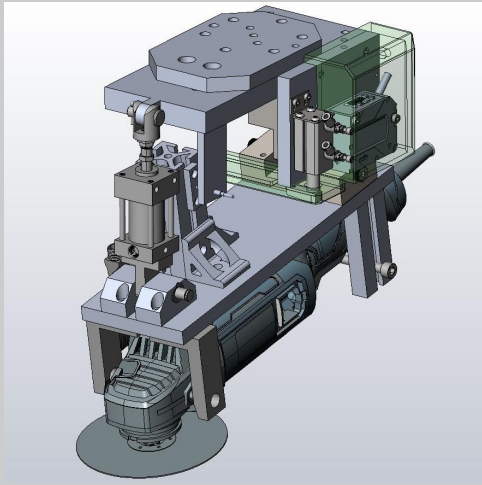

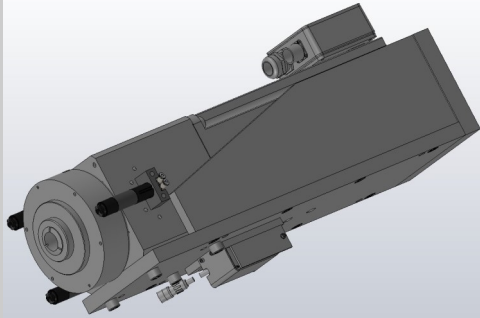

LARGE SERVO SPINDLE WITH AUTO COLLET - SPD-16285-4111

Large spindle tool with closed loop servo driven pneumatically activated collet which allows for automatic media change. Equivalent power rating to 13.5 HP and speed range 0-4000 RPM makes this spindle a perfect choice for a variety of applications like grinding, buffing, deburring, polishing, or cutting. The tool is equipped with 1" (25mm) collet and combined with media staging nests has the capability to automatically change worn wheels, brushes, buffs and other finishing media.

- Servo with feedback for closed loop speed control
- Continuous torque: 265 lb-in (30 Nm)
- Speed range: 0-4000 RPM
- Pneumatically operated collet
- Standard collet size: 1" (25mm)
- Speed and torque feedback through servo motor drive
- Sensors for collet opened and closed
- Optional distance laser sensor with dust cover
- Mounting directly to robot EOA or tool change adapter
- No cooling is required.

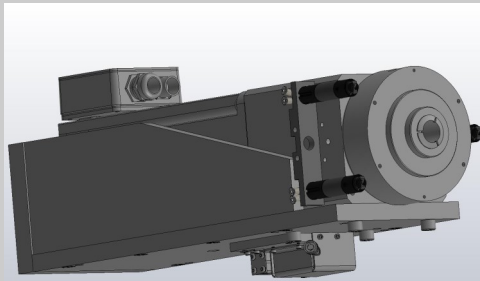

LARGE SERVO SPINDLE - SPD-2011212-100

Large high torque spindle tool with closed loop servo driving output shaft where abrasive wheels are manually mounted. High continuous torque and speed range 0-1350 RPM makes this spindle a perfect choice for variety of applications like grinding, buffing, deburring, polishing, or cutting. In particular this tool is ideal for heavy grinding with stone wheels. Optional pivoting compliance would ease programming with grinding wheel applying commanded force to the part while compensating for inaccuracies in part surfaces.

- Servo with feedback for closed loop speed control
- Continuous torque: 795 lb-in (90 Nm)
- Speed range: 0-1350 RPM. Standard shaft size: 1.25" (32mm)
- Speed and torque feedback through servo motor drive
- Sensors for collet opened and closed
- Optional distance laser sensor with dust cover
- Optional pivot style compliance float
- Mounting directly to robot EOA or tool change adapter
- No cooling is required

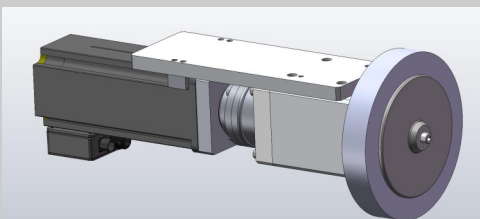
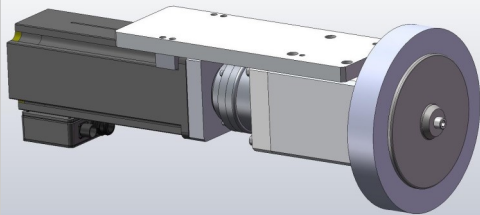

End of Arm: Grippers

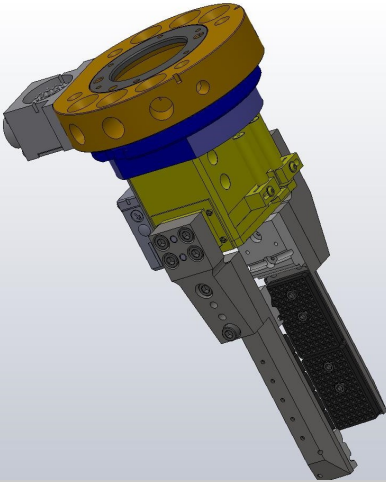

SMALL 2-JAW GRIPPER TOOL - GRP-RP17-TC

Two jaw RP17 gripper assembly with tool changer and plates for 45 degree docking nests. Supplied with tool change adapter fully plumbed and wired and 2 digit binary signals identification number.

- 2-jaw gripper with viton seals
- Grip force: 220 lbs (978 N)
- Total stroke: 0.75" (19.1 mm)
- ATI tool change adapter standard
- Other tool changers optional
- 2-digit tool identification number with tool changer
- Standard PNP sensors: gripper opened and closed
- Plumbed and wired

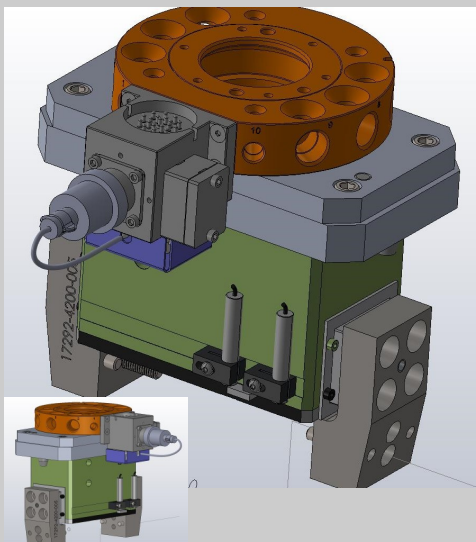

MEDIUM 2-JAW GRIPPER TOOL - GRP-RP18-TC

Two jaw RP18 gripper assembly with tool changer and plates for horizontal docking nests. Supplied with tool change adapter fully plumbed and wired and 2 digit binary signals identification number.

- 2-jaw gripper with viton seals
- Grip force: 400 lbs (1779 N)
- Total stroke: 1.25" (31.8 mm)
- ATI tool change adapter standard
- Other tool changers optional
- 2-digit tool identification number with tool changer
- Standard PNP sensors: gripper opened and closed
- Plumbed and wired.

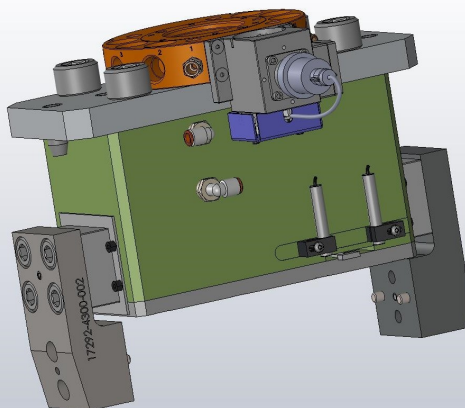

LARGE 2-JAW GRIPPER TOOL - GRP-RP19-TC

Two jaw RP19 gripper assembly with tool changer and plates for horizontal docking nests. Supplied with tool change adapter fully plumbed and wired and 2 digit binary signals identification number.

- 2-jaw gripper with viton seals
- Grip force: 600 lbs (2669 N)
- Total stroke: 2.0" (50.8 mm)
- ATI tool change adapter standard
- Other tool changers optional
- 2-digit tool identification number with tool changer
- Standard PNP sensors: gripper opened and closed
- Plumbed and wired

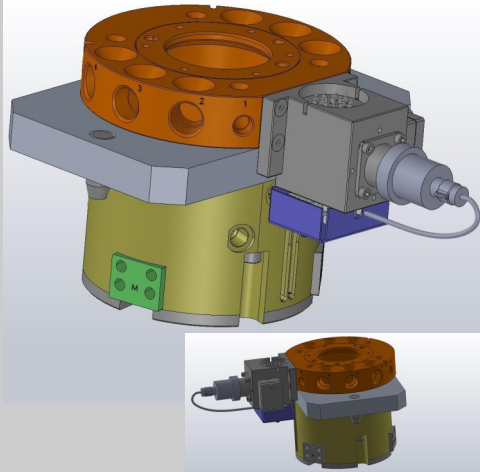

MEDIUM 3-JAW GRIPPER TOOL - GRP-RPC-TC

Three jaw RPC gripper assembly with tool changer and plates for horizontal docking nests. Supplied with tool change adapter fully plumbed and wired and 2 digit binary signals identification number.

- 3-jaw gripper with viton seals
- Grip force: 900 lbs (4003 N)
- Total stroke: 0.88" (22.35 mm)
- ATI tool change adapter standard
- Other tool changers optional
- 2-digit tool identification number with tool changer
- Standard PNP sensors: gripper opened ad closed
- Plumbed and wired

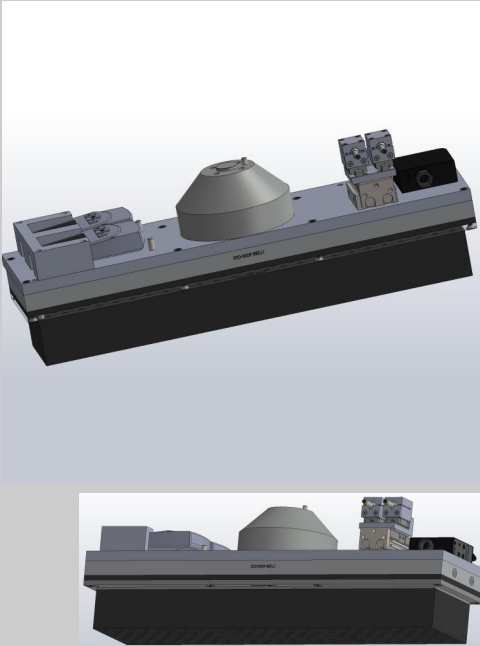

VACUUM SHEET GRIPPER TOOL - GRP-VAC-17288

Vacuum gripper for handling thin sheets or foils. Holes in soft pad provide vacuum suction while allowing compliance during sheet picking. Vacuum generator with feedback included. Optional eddy current probes.

- Standard overall size: 20" x 5.875" (508 x 149 mm)
- Gripping surface size: 19" x 4" (483 x 102 mm)
- Applications: handling of thin sheets or foils using vacuum
- Attaches directly to robot EOA
- Vacuum delivered through series of holes in soft rubber pad
- Vacuum generator with signals for product gripped, display and settings keys, blow-off function for product release
- Optional eddy current probe SENS-17288-5012

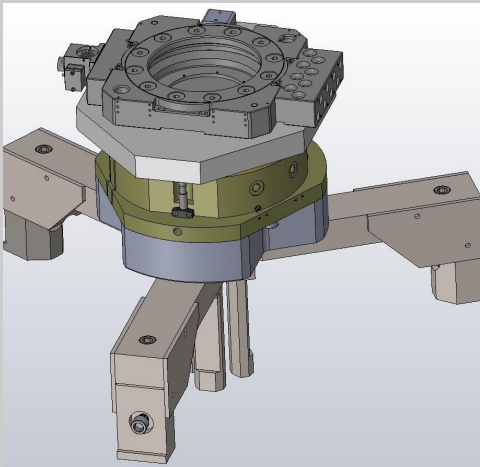

LARGE 3-JAW GRIPPER TOOL - GRP-18297-4001

Large 3-jaw RTH-8M-L gripper assembly with tool changer and plates for horizontal docking nests. Supplied with tool change adapter fully plumbed and wired and 2 digit binary signals identification number.

- 3-jaw gripper with viton seals
- Grip force: 6450 lbs (28691N)
- Total stroke: 2.76" (70.1 mm)
- ATI tool change adapter standard
- Other tool changers optional
- 2-digit tool identification number with tool changer
- Standard PNP sensors: gripper opened ad closed, tool changer coupled and uncoupled
- Plumbed and wired.

Buffing Tools and Stations

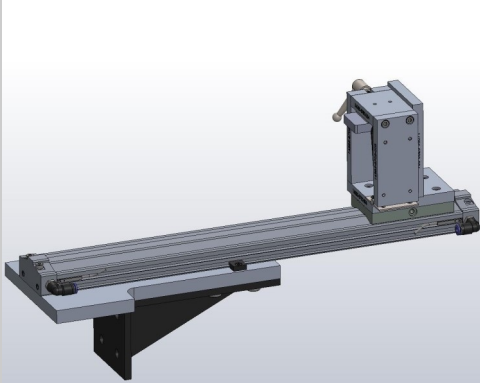

COMPOUND APPLICATOR FOR SOLID BARS - BUFF-CMPDX1-16285-8702

Solid compound bar applicator with pneumatic pressure control extension and front guides/support for the compound bar. The applicator extends to press compound bar against a buff under programmed force. As the compound bar wears the applicator advances constantly applying the set force. Application cycle and the force are controlled by the machine controller.

- Standard compound bars range: 2.62"x1.75" (66.5 x 44.5 mm) to 3" x 2" (76 x 50 mm) and up to 12" (305 mm) long
- Application force: up to 28 lbs (12.7 kg)
- Supports for bar tip during application to prevent breakage
- Maximum compound bar wear sensor (maximum extension)
- Retracted sensor

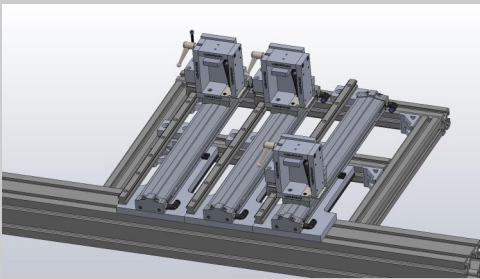

TRIPLE COMPOUND APPLICATOR - BUFF-CMPDX3-16285-8713

Station with 3 solid bar compound applicators (BUFF-CMPDX1-16285-8702) with independent pneumatic pressure control extension and front guides/support for the compound bar. Each compound applicator is controlled separately so only one bar extends for application at a time. Each applicator extends to press compound bar against a buff under programmed force. As the compound bar wears the applicator advances constantly applying the set force. Application cycle and the force are controlled by the machine controller.

- The station allows application of up to 3 different compounds
- Each applicator specifications
- Standard compound bars range: 2.62"x1.75" (66.5 x 44.5 mm) to 3" x 2" (76 x 50 mm) and up to 12" (305 mm) long
- Application force: up to 28 lbs (12.7 kg)
- Supports for bar tip during application to prevent breakage
- Maximum compound bar wear sensor (maximum extension)
- Retracted sensor
- Optional fully plumbed and wired ready for use
- Available controls are: discrete I/O, Ethernet I/P, Profibus, Devicenet

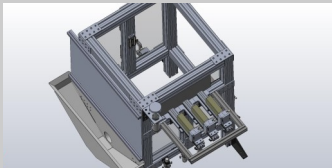
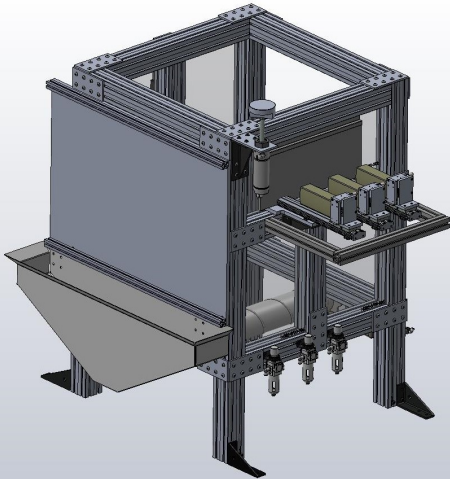

COMPOUND APPLICATION AND BUFF TREATMENT STATION - BUFF-STATION-16285-8700

Booth-style station for treating buff wheels and applying compound accessible through the top opening. Included are triple bar compound application station (BUFF-CMPDX3-16285-8713), buff rake, buff smoothing plate, dust collection scoop.

- Overall station size: 31.5" x 31.5" x 47" (800 x 800 x 1194 mm)
- Top opening: 25.5" x 25.5" (648 x 648 mm)
- One triple compound bar applicator #BUFF-CMPDX3-16285-8713
- One 9" (229 mm) long buff rake
- One 35.5" x 24" (902 x 610 mm) plate with sandpaper for buff surface cleanup
- Dust scoop
- Optional fully plumbed and wired ready for use
- Available controls are: discrete I/O, Ethernet I/P, Profibus, Devicenet

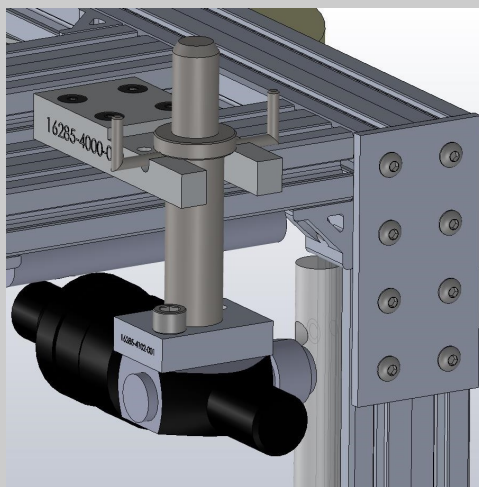

COMPOUND SPRAY GUN ARBOR - BUFF-SPRAY-16285-4102

Compound spray gun attachment on 1" arbor for spindle #SPD-16285-4111. The attachment can be picked up by the spindle and with umbilical cords for air, signals, and compound allows manipulation by the robot with that spindle. Optional takeup roller for the umbilical cabling makes this a compact system for articulated spray of liquid compound.

- 1" diameter arbor for handling by auto collet spindle SPD-16285-4111
- High pressure or low pressure spray gun
- Umbilical cord for air, electric signals, and compound delivery extends 90" (2280 mm) allowing that much motion
- Optional compound pressure tank
- Optional umbilical cord take-up roller

Disk Handling and Sandpaper Feeder

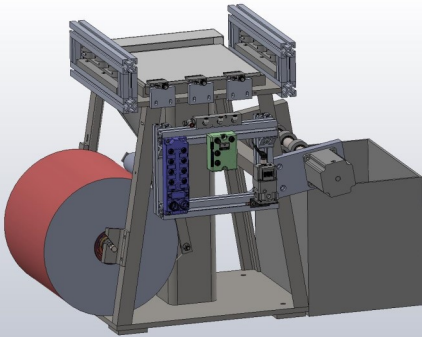

SANDPAPER FEEDER AND GRINDER - FDR-18301-6100

Sandpaper roller feeder with precise flat grinding plate. Clamps on both ends of the plate ensure tight and flat stretch of sandpaper across the plate. Sensors detect feed distance and empty roller. Customer supplies collection bin at output for used sandpaper.

- Dimensions without sandpaper roll: 24" x 21" x 28" (610 x 533 x 711 mm)
- Dimensions with sandpaper roll: 31" x 21" x 28" (787 x 533 x 711 mm)
- Sandpaper roll width: 12" (305 mm)
- Recommended max roll diameter: 14" (355 mm)
- Motorized sandpaper feed with rotation sensor
- Clamps on grinding plate entry and exit to keep paper tight during sanding
- Roller empty sensor
- Optional fully plumbed and wired ready for use
- Available controls are: discrete I/O, Ethernet I/P, Profibus, Devicenet

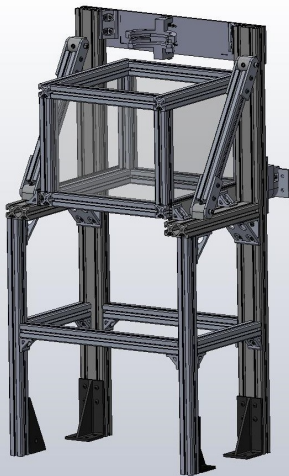

DISK PEELER STATION - DISK-17288-8000

This station is for automatic peeling of the Hook&Loop (velcro) style disks using an articulated motion by a robotic arm. It handles 5" (127 mm) and 3" (76 mm) disks. Used disks fall into a collection drawer which can be emptied by operator from outside the cell.

- Overall dimensions with stand: 23" x 17.75" x 45.5" (584 x 451 x 1156 mm)
- Drawer outside dimensions: 16" wide x 16.25" deep x 13" high (406 x 413 x 330 mm)
- Standard sensors PNP type: disk gripper open/close, drawer closed, discard drawer full
- Electromagnetic locks to hold drawer closed
- Optional fully plumbed and wired ready for use
- Available controls are: discrete I/O, Ethernet I/P, Profibus, Devicenet

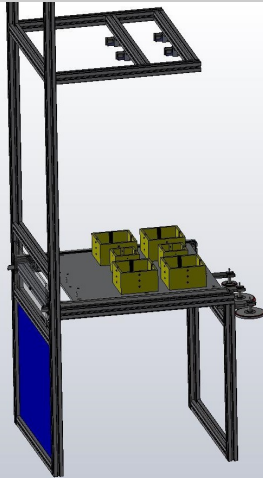

DISK LOAD STATION - DISK-17288-4002

Station with drawer for loading hook&loop style disks of 5" (127 mm) and 3" (76 mm) diameters and 3 docking nests with sensors for hook&loop pads with arbors. Drawer with disk magazines can be opened by operator from outside the cell to reload abrasive disks. Upon closing the drawer is kept locked using electromagnet. Optional attachment with overhead sensors for detecting disk magazines empty.

- Station size without overhead sensors: 27" wide x 33" deep x 32" high (686 x 838 x 813 mm)
- Dimensions with overhead sensor attachment: 27" x 33" x 96" (686 x 838 x 2438 mm)
- Up to 6 disk magazines # DISK-17288-4003-4010 positioned for robot access (any combination of 3" and 5")
- 3 pads arbor docking nests with sensors # DISK-17288-4000-008
- Mechanical or electromagnetic lock of the drawer
- Sensors for drawer closed position
- Optional fully plumbed and wired ready for use
- Available controls are: discrete I/O, Ethernet I/P, Profibus, Devicenet.

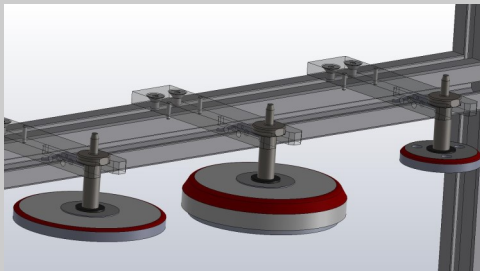

DISK PAD ARBORS - DISK-17288-4004-4008

Arbors with hook&loop pads. 1/4" (6mm) arbor diameter with flats for wrench to assist with pad changes. Use suffix -3 for 3" pads and -5 for 5".

- Arbor mount: hook and loop pads with threaded stems
- Arbor diameter: 1/4" (6mm)
- Arbor length: 2.25" (57 mm)
- Available with backup pads modified for automatic disc peeling
- Available in 3" and 5" diameters and hard and medium grades

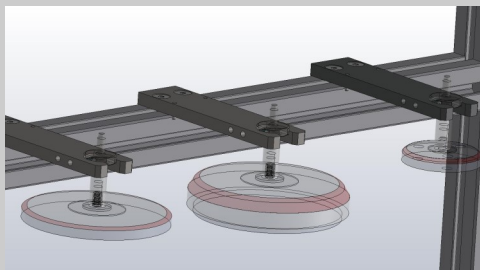

DISK PAD ARBOR DOCKING NEST - DISK-17288-4000-008

Docking nests with sensors for pad arbors # DISK-17288-4004-4008. Nests have pockets for capturing and locating of arbors and sensors for presence detection.

- Mounts to standard slotted aluminum framing
- Overall size: 6" long x 1.5" wide x 1/4" thick (152.4 x 38 x 6 mm)

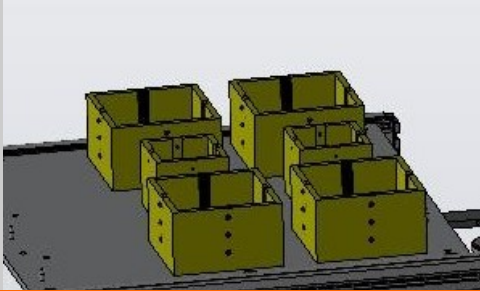
**DISK MAGAZINES - DISK-17288-4003-4010**

Disk magazines where fresh disks are stacked and top one is picked up by robot handling arbor with corresponding pad. Design of the magazines prevents disk curling keeping them flat for proper pickups. Compliance provides easier platform for pressing pad against disk during pick. Photoeye reflector at bottom of the magazine for sensing empty condition. Use suffix -3 for 3" disks and -5 for 5".

- Magazine sized for 3" and 5" disks
- Internal height: 2.88" (73 mm)
- Capacity: 100 hook&loop disks
- Internal features reduce disk stack curling to keep them as flat as possible for proper pickup
- Polarized reflector in the bottom for magazine empty detection using photo sensors

**Custom Engineered
Solutions**

**Need something that you didn't see here? Or
need something more application specific?**

Send us an email or give us a call! We will leverage our years of industry expertise and our extensive process knowledge to help specify and design the perfect stations and tooling tailored to your specific needs.

Www.z3dsolutions.com

Email: sales@z3dsolutiuons.com

Phone:(860)-380-0198



SCAN ME